

***SYLVANIA***

# **SERVICE MANUAL**

**13" COLOR TELEVISION**

**6413CTB**

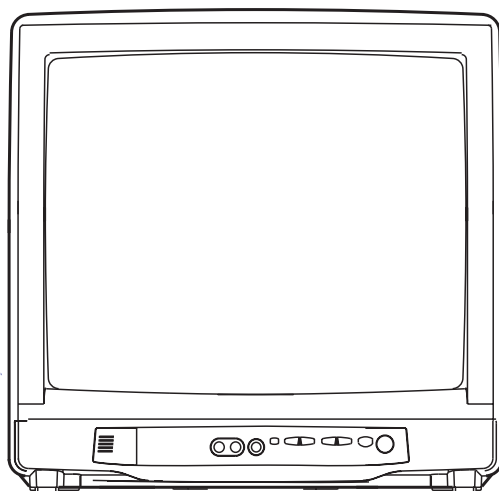

# IMPORTANT SAFETY NOTICE

Proper service and repair is important to the safe, reliable operation of all Funai Equipment. The service procedures recommended by Funai and described in this service manual are effective methods of performing service operations. Some of these service special tools should be used when and as recommended.

It is important to note that this service manual contains various CAUTIONS and NOTICES which should be carefully read in order to minimize the risk of personal injury to service personnel. The possibility exists that improper service methods may damage the equipment. It also is important to understand that these CAUTIONS and NOTICES ARE NOT EXHAUSTIVE. Funai could not possibly know, evaluate and advise the service trade of all conceivable ways in which service might be done or of the possible hazardous consequences of each way. Consequently, Funai has not undertaken any such broad evaluation. Accordingly, a servicer who uses a service procedure or tool which is not recommended by Funai must first use all precautions thoroughly so that neither his safety nor the safe operation of the equipment will be jeopardized by the service method selected.

## TABLE OF CONTENTS

Specifications.....	1-1	CBA Views and Test Points .....	7-9
Important Safety Precautions.....	2-1	Wave Forms .....	8-1
Standard Notes for Servicing .....	3-1	Wiring Diagram.....	9-1
Cabinet Disassembly Instructions.....	4-1	IC Pin Fuction.....	10-1
Electrical Adjustment Instructions .....	5-1	Cabinet Exploded View .....	11-1
Block Diagram.....	6-1	Packing Exploded View .....	11-5
Schematic Diagram / CBA's and Test Points .....	7-1	Mechanical Parts List .....	12-1
Schematic Diagram .....	7-3	Electrical Parts List.....	13-1

# SPECIFICATIONS

## < TUNER >

ANT. Input ----- 75ohm Unbal., F type  
 Reference Level ----- 20Vp-p (CRT Green Cathode)  
 Test Input Signal ----- 400Hz 30% modulation

Description	Condition	Unit	Nominal	Limit
1. Intermediate Freq.	Picture	MHz	45.75	—
	Sound	MHz	41.25	—
2. Peak Picture Sens	VHF	dB $\mu$ V	15	30
	CATV	dB $\mu$ V	15	30
	UHF	dB $\mu$ V	15	40
3. AFT Pull In Range (10mV input)	—	MHz	$\pm$ 2.0	$\pm$ 0.7

## < DEFLECTION >

Description	Condition	Unit	Nominal	Limit
1. Deflection Freq.	Horizontal	KHz	15.734	—
	Vertical	Hz	60	—
2. Linearity	Horizontal	%	—	$\pm$ 15
	Vertical	%	—	$\pm$ 10
3. Over Scan	—	%	10	—
4. High Voltage	—	KV	23	—

## < VIDEO & CHROMA >

Description	Condition	Unit	Nominal	Limit
1. Misconvergence	Center	mm	—	0.3
	Side	mm	—	1.2
	Corner	mm	—	1.5
2. Brightness	APL 100%	Ft-L	60	40
3. Color Temperature	—	$^{\circ}$ K	9200 $^{\circ}$ K	—
4. Resolution	Horizontal	Line	250	—
	Vertical	Line	300	—

## < AUDIO >

All items are measured across 8 $\Omega$  load at speaker output terminal.

Description	Condition	Unit	Nominal	Limit
1. Audio Output Power	10% THD	W	1	0.8
2. Audio Distortion (w/LPF)	500mW	%	2	7
3. Audio Freq. Response	-3dB	Hz	100~11K	—

### Note:

Nominal specifications represent the design specifications. All units should be able to approximate these. Some will exceed and some may drop slightly below these specifications. Limit specifications represent the absolute worst condition that still might be considered acceptable. In no case should a unit fail to meet limit specifications.

# IMPORTANT SAFETY PRECAUTIONS

Prior to shipment from the factory, our products are strictly inspected for recognized product safety and electrical codes of the countries in which they are to be sold. However, in order to maintain such compliance, it is equally important to implement the following precautions when a set is being serviced.

## Safety Precautions for TV Circuit

**1. Before returning an instrument to the customer,** always make a safety check of the entire instrument, including, but not limited to, the following items:

**a.** Be sure that no built-in protective devices are defective and have been defeated during servicing. (1) Protective shields are provided on this chassis to protect both the technician and the customer. Correctly replace all missing protective shields, including any removed for servicing convenience. (2) When reinstalling the chassis and/or other assembly in the cabinet, be sure to put back in place all protective devices, including but not limited to, non-metallic control knobs, insulating fishpapers, adjustment and compartment covers/shields, and isolation resistor/capacitor networks. **Do not operate this instrument or permit it to be operated without all protective devices correctly installed and functioning. Servicers who defeat safety features or fail to perform safety checks may be liable for any resulting damage.**

**b.** Be sure that there are no cabinet openings through which an adult or child might be able to insert their fingers and contact a hazardous voltage. Such openings include, but are not limited to, (1) spacing between the picture tube and the cabinet mask, (2) excessively wide cabinet ventilation slots, and (3) an improperly fitted and/or incorrectly secured cabinet back cover.

**c. Antenna Cold Check** - With the instrument AC plug removed from any AC source, connect an electrical jumper across the two AC plug prongs. Place the instrument AC switch in the on position. Connect one lead of an ohmmeter to the AC plug prongs tied together and touch the other ohmmeter lead in turn to each tuner antenna input exposed terminal screw and, if applicable, to the coaxial connector. If the measured resistance is less than 1.0 megohm or greater than 5.2 megohm, an abnormality exists that must be corrected before the instrument is returned to the customer. Repeat this test with the instrument AC switch in the off position.

**d. Leakage Current Hot Check** - With the instrument completely reassembled, plug the AC line cord directly into a 120V AC outlet. (Do not use an isolation transformer during this test.) Use a leakage

current tester or a metering system that complies with American National Standards Institute (ANSI) C101.1 Leakage Current for Appliances and Underwriters Laboratories (UL) 1410, (50.7). With the instrument AC switch first in the on position and then in the off position, measure from a known earth ground (metal water pipe, conduit, etc.) to all exposed metal parts of the instrument (antennas, handle brackets, metal cabinet, screw heads, metallic overlays, control shafts, etc.), especially any exposed metal parts that offer an electrical return path to the chassis. Any current measured must not exceed 0.5 milli-ampere. Reverse the instrument power cord plug in the outlet and repeat the test.

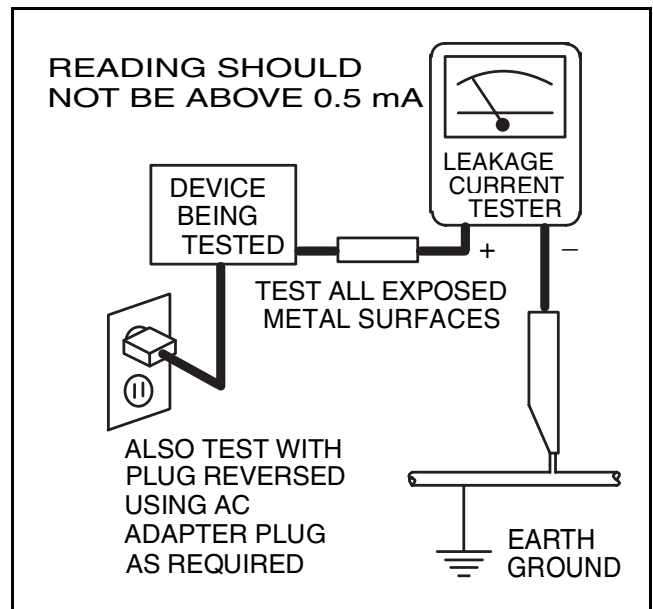

**ANY MEASUREMENTS NOT WITHIN THE LIMITS SPECIFIED HEREIN INDICATE A POTENTIAL SHOCK HAZARD THAT MUST BE ELIMINATED BEFORE RETURNING THE INSTRUMENT TO THE CUSTOMER OR BEFORE CONNECTING THE ANTENNA OR ACCESSORIES.**

**e. X-Radiation and High Voltage Limits** - Because the picture tube is the primary potential source of X-radiation in solid-state TV receivers, it is specially constructed to prohibit X-radiation emissions. For continued X-radiation protection, the replacement picture tube must be the same type as the original. Also, because the picture tube shields and mounting hardware perform an X-radiation protection function, they must be correctly in place. High voltage must be measured each time servicing

is performed that involves B+, horizontal deflection or high voltage. Correct operation of the X-radiation protection circuits also must be reconfirmed each time they are serviced. (X-radiation protection circuits also may be called "horizontal disable" or "hold down.") Read and apply the high voltage limits and, if the chassis is so equipped, the X-radiation protection circuit specifications given on instrument labels and in the Product Safety & X-Radiation Warning note on the service data chassis schematic. High voltage is maintained within specified limits by close tolerance safety-related components/adjustments in the high-voltage circuit. If high voltage exceeds specified limits, check each component specified on the chassis schematic and take corrective action.

2. Read and comply with all caution and safety-related notes on or inside the receiver cabinet, on the receiver chassis, or on the picture tube.

**3. Design Alteration Warning** - Do not alter or add to the mechanical or electrical design of this TV receiver. Design alterations and additions, including, but not limited to circuit modifications and the addition of items such as auxiliary audio and/or video output connections, might alter the safety characteristics of this receiver and create a hazard to the user. Any design alterations or additions will void the manufacturer's warranty and may make you, the servicer, responsible for personal injury or property damage resulting therefrom.

**4. Picture Tube Implosion Protection Warning** - The picture tube in this receiver employs integral implosion protection. For continued implosion protection, replace the picture tube only with one of the same type number. Do not remove, install, or otherwise handle the picture tube in any manner without first putting on shatterproof goggles equipped with side shields. People not so equipped must be kept safely away while picture tubes are handled. Keep the picture tube away from your body. Do not handle the picture tube by its neck. Some "in-line" picture tubes are equipped with a permanently attached deflection yoke; because of potential hazard, do not try to remove such "permanently attached" yokes from the picture tube.

**5. Hot Chassis Warning -**

a. Some TV receiver chassis are electrically connected directly to one conductor of the AC power cord and may be safety-serviced without an isolation transformer only if the AC power plug is inserted so that the chassis is connected to the ground side of the AC power source. To confirm that the AC power plug is inserted correctly, with an AC voltmeter, measure between the chassis and a known earth

ground. If a voltage reading in excess of 1.0V is obtained, remove and reinsert the AC power plug in the opposite polarity and again measure the voltage potential between the chassis and a known earth ground.

b. Some TV receiver chassis normally have 85V AC(RMS) between chassis and earth ground regardless of the AC plug polarity. This chassis can be safety-serviced only with an isolation transformer inserted in the power line between the receiver and the AC power source, for both personnel and test equipment protection.

c. Some TV receiver chassis have a secondary ground system in addition to the main chassis ground. This secondary ground system is not isolated from the AC power line. The two ground systems are electrically separated by insulation material that must not be defeated or altered.

6. Observe original lead dress. Take extra care to assure correct lead dress in the following areas: a. near sharp edges, b. near thermally hot parts-be sure that leads and components do not touch thermally hot parts, c. the AC supply, d. high voltage, and e. antenna wiring. Always inspect in all areas for pinched, out of place, or frayed wiring. Check AC power cord for damage.

7. Components, parts, and/or wiring that appear to have overheated or are otherwise damaged should be replaced with components, parts, or wiring that meet original specifications. Additionally, determine the cause of overheating and/or damage and, if necessary, take corrective action to remove any potential safety hazard.

**8. Product Safety Notice** - Some electrical and mechanical parts have special safety-related characteristics which are often not evident from visual inspection, nor can the protection they give necessarily be obtained by replacing them with components rated for higher voltage, wattage, etc.. Parts that have special safety characteristics are identified by a (▲) on schematics and in parts lists. Use of a substitute replacement that does not have the same safety characteristics as the recommended replacement part might create shock, fire, and/or other hazards. The product's safety is under review continuously and new instructions are issued whenever appropriate. Prior to shipment from the factory, our products are strictly inspected to confirm they comply with the recognized product safety and electrical codes of the countries in which they are to be sold. However, in order to maintain such compliance, it is equally important to implement the following precautions when a set is being serviced.

## Precautions during Servicing

**A.** Parts identified by the ( ▲ ) symbol are critical for safety.

Replace only with part number specified.

**B.** In addition to safety, other parts and assemblies are specified for conformance with regulations applying to spurious radiation. These must also be replaced only with specified replacements.

Examples: RF converters, RF cables, noise blocking capacitors, and noise blocking filters, etc.

**C.** Use specified internal wiring. Note especially:

- 1) Wires covered with PVC tubing
- 2) Double insulated wires
- 3) High voltage leads

**D.** Use specified insulating materials for hazardous live parts. Note especially:

- 1) Insulation Tape
- 2) PVC tubing
- 3) Spacers
- 4) Insulators for transistors.

**E.** When replacing AC primary side components (transformers, power cord, etc.), wrap ends of wires securely about the terminals before soldering.

**F.** Observe that the wires do not contact heat producing parts (heatsinks, oxide metal film resistors, fusible resistors, etc.)

**G.** Check that replaced wires do not contact sharp edged or pointed parts.

**H.** When a power cord has been replaced, check that 5~6 kg of force in any direction will not loosen it.

**I.** Also check areas surrounding repaired locations.

**J.** Use care that foreign objects (screws, solder droplets, etc.) do not remain inside the set.

**K.** Crimp type wire connector

The power transformer uses crimp type connectors which connect the power cord and the primary side of the transformer. When replacing the transformer, follow these steps carefully and precisely to prevent shock hazards.

Replacement procedure

- 1) Remove the old connector by cutting the wires at a point close to the connector.

Important: Do not re-use a connector (discard it).

- 2) Strip about 15 mm of the insulation from the ends of the wires. If the wires are stranded, twist the strands to avoid frayed conductors.

- 3) Align the lengths of the wires to be connected. Insert the wires fully into the connector.

- 4) Use the crimping tool to crimp the metal sleeve at the center position. Be sure to crimp fully to the complete closure of the tool.

**L.** When connecting or disconnecting the internal connectors, first, disconnect the AC plug from the AC supply outlet.

## Safety Check after Servicing

Examine the area surrounding the repaired location for damage or deterioration. Observe that screws, parts and wires have been returned to original positions. Afterwards, perform the following tests and confirm the specified values in order to verify compliance with safety standards.

### 1. Clearance Distance

When replacing primary circuit components, confirm specified clearance distance (d) and (d') between soldered terminals, and between terminals and surrounding metallic parts. (See Fig. 1)

**Table 1 : Ratings for selected area**

AC Line Voltage	Region	Clearance Distance (d) (d')
110 to 130 V	USA or CANADA	$\geq 3.2$ mm (0.126 inches)

**Note:** This table is unofficial and for reference only. Be sure to confirm the precise values.

### 2. Leakage Current Test

Confirm the specified (or lower) leakage current between B (earth ground, power cord plug prongs) and externally exposed accessible parts (RF terminals, antenna terminals, video and audio input and output terminals, microphone jacks, earphone jacks, etc.) is lower than or equal to the specified value in the table below.

#### Measuring Method : (Power ON)

Insert load Z between B (earth ground, power cord plug prongs) and exposed accessible parts. Use an AC voltmeter to measure across both terminals of load Z. See Fig. 2 and following table.

**Table 2 : Leakage current ratings for selected areas**

AC Line Voltage	Region	Load Z	Leakage Current (i)	Earth Ground (B) to:
110 to 130 V	USA	0.15 $\mu$ F CAP. & 1.5k $\Omega$ RES. connected in parallel	$i \leq 0.5$ mA rms	Exposed accessible parts

**Note:** This table is unofficial and for reference only. Be sure to confirm the precise values.

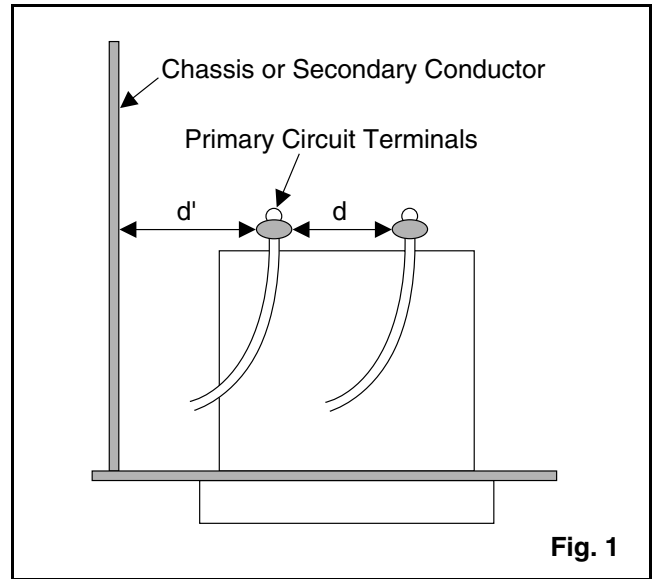

**Fig. 1**

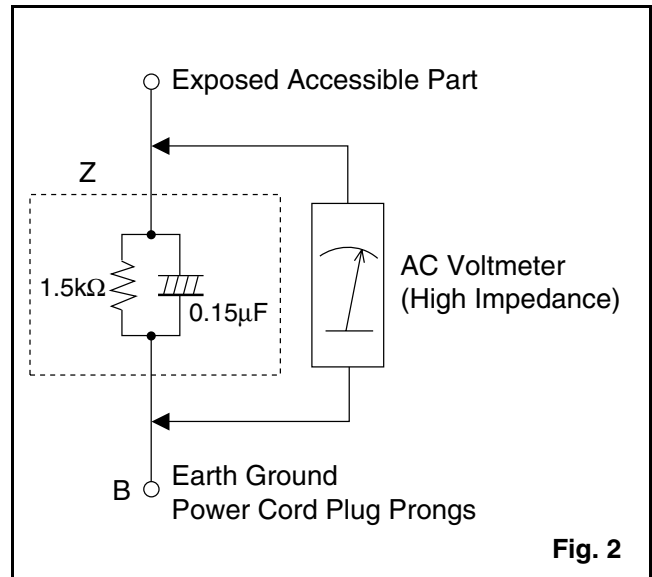
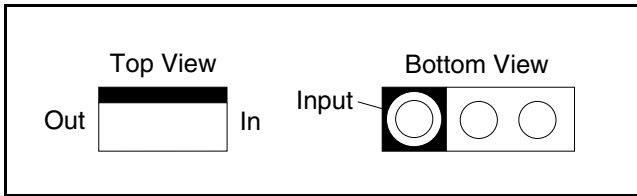

**Fig. 2**

# STANDARD NOTES FOR SERVICING

## Circuit Board Indications

a. The output pin of the 3 pin Regulator ICs is indicated as shown.



b. For other ICs, pin 1 and every fifth pin are indicated as shown.

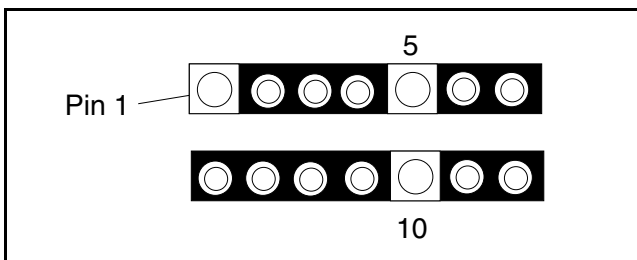

c. The 1st pin of every male connector is indicated as shown.

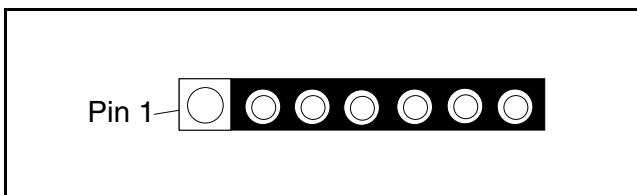

## How to Remove / Install Flat Pack-IC

### 1. Removal

With Hot-Air Flat Pack-IC Desoldering Machine:

- (1) Prepare the hot-air flat pack-IC desoldering machine, then apply hot air to the Flat Pack-IC (about 5 to 6 seconds). (Fig. S-1-1)

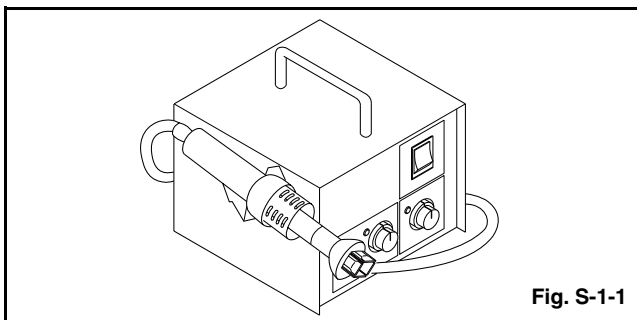

Fig. S-1-1

- (2) Remove the flat pack-IC with tweezers while applying the hot air.
- (3) Bottom of the flat pack-IC is fixed with glue to the CBA; when removing entire flat pack-IC, first apply soldering iron to center of the flat pack-IC and heat up. Then remove (glue will be melted). (Fig. S-1-6)
- (4) Release the flat pack-IC from the CBA using tweezers. (Fig. S-1-6)

### Caution:

1. Do not supply hot air to the chip parts around the flat pack-IC for over 6 seconds because damage to the chip parts may occur. Put masking tape around the flat pack-IC to protect other parts from damage. (Fig. S-1-2)
2. The flat pack-IC on the CBA is affixed with glue, so be careful not to break or damage the foil of each pin or the solder lands under the IC when removing it.

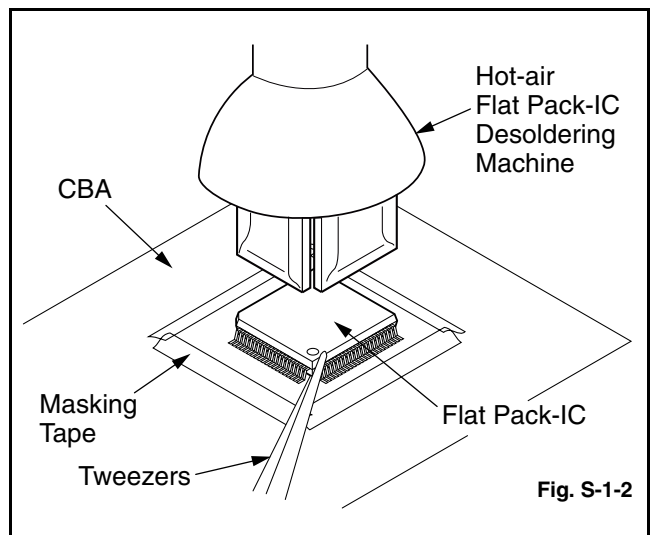
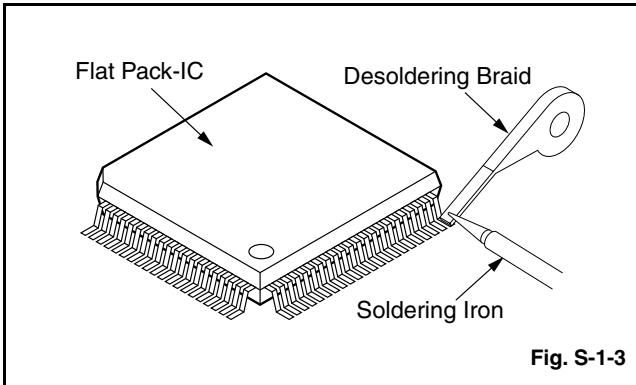

Fig. S-1-2



### With Soldering Iron:

- (1) Using desoldering braid, remove the solder from all pins of the flat pack-IC. When you use solder flux which is applied to all pins of the flat pack-IC, you can remove it easily. (Fig. S-1-3)



- (2) Lift each lead of the flat pack-IC upward one by one, using a sharp pin or wire to which solder will not adhere (iron wire). When heating the pins, use a fine tip soldering iron or a hot air desoldering machine. (Fig. S-1-4)

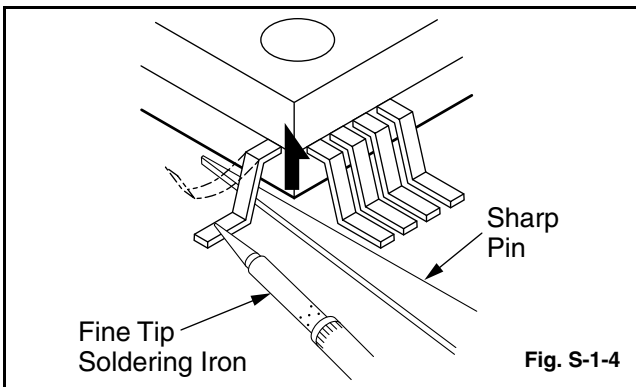

- (3) Bottom of the flat pack-IC is fixed with glue to the CBA; when removing entire flat pack-IC, first apply soldering iron to center of the flat pack-IC and heat up. Then remove (glue will be melted). (Fig. S-1-6)
- (4) Release the flat pack-IC from the CBA using tweezers. (Fig. S-1-6)

### With Iron Wire:

- (1) Using desoldering braid, remove the solder from all pins of the flat pack-IC. When you use solder flux which is applied to all pins of the flat pack-IC, you can remove it easily. (Fig. S-1-3)
- (2) Affix the wire to a workbench or solid mounting point, as shown in Fig. S-1-5.
- (3) While heating the pins using a fine tip soldering iron or hot air blower, pull up the wire as the solder melts so as to lift the IC leads from the CBA contact pads as shown in Fig. S-1-5.
- (4) Bottom of the flat pack-IC is fixed with glue to the CBA; when removing entire flat pack-IC, first apply

soldering iron to center of the flat pack-IC and heat up. Then remove (glue will be melted). (Fig. S-1-6)

- (5) Release the flat pack-IC from the CBA using tweezers. (Fig. S-1-6)

### Note:

When using a soldering iron, care must be taken to ensure that the flat pack-IC is not being held by glue. When the flat pack-IC is removed from the CBA, handle it gently because it may be damaged if force is applied.

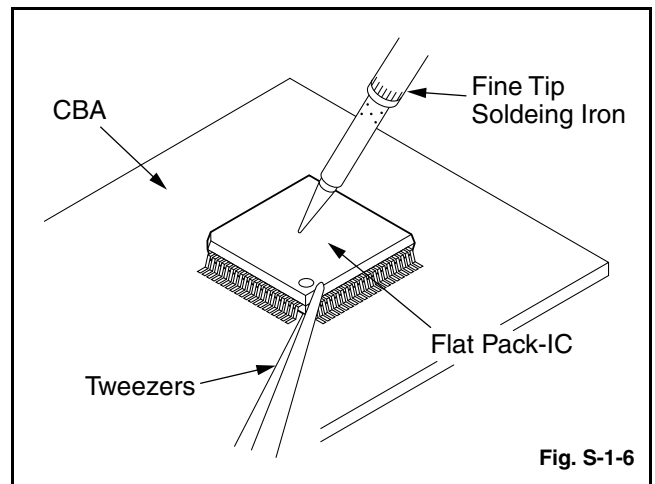
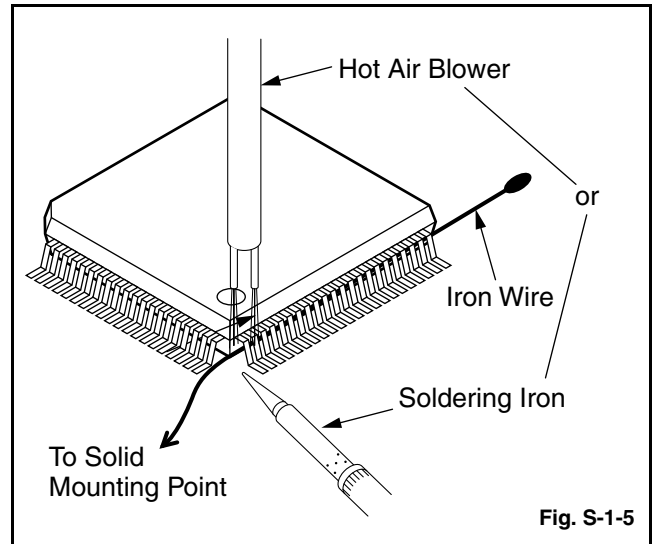

## 2. Installation

- (1) Using desoldering braid, remove the solder from the foil of each pin of the flat pack-IC on the CBA so you can install a replacement flat pack-IC more easily.
- (2) The "●" mark on the flat pack-IC indicates pin 1. (See Fig. S-1-7.) Be sure this mark matches the 1 on the PCB when positioning for installation. Then pre-solder the four corners of the flat pack-IC. (See Fig. S-1-8.)
- (3) Solder all pins of the flat pack-IC. Be sure that none of the pins have solder bridges.

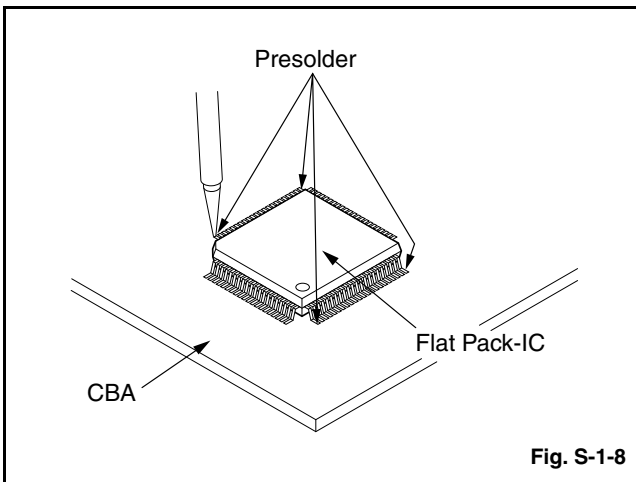
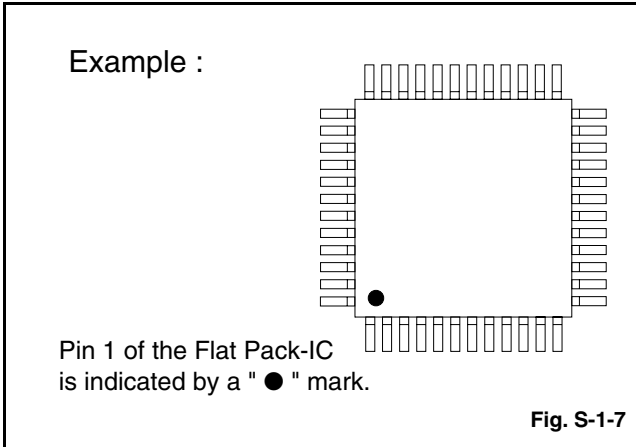

## Instructions for Handling Semiconductors

Electrostatic breakdown of the semiconductors may occur due to a potential difference caused by electrostatic charge during unpacking or repair work.

### 1. Ground for Human Body

Be sure to wear a grounding band ( $1M\Omega$ ) that is properly grounded to remove any static electricity that may be charged on the body.

### 2. Ground for Workbench

Be sure to place a conductive sheet or copper plate with proper grounding ( $1M\Omega$ ) on the workbench or other surface, where the semiconductors are to be placed. Because the static electricity charge on clothing will not escape through the body grounding band, be careful to avoid contacting semiconductors with your clothing.

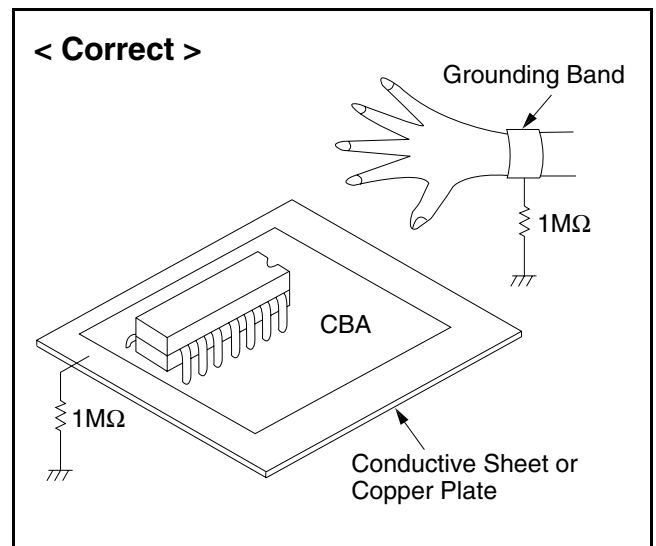
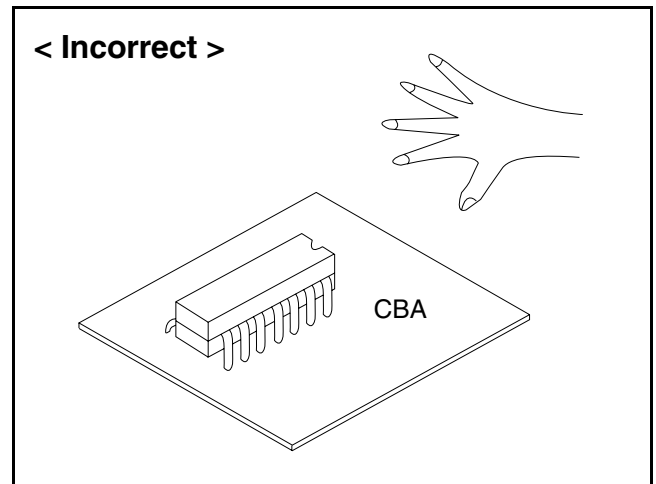

# CABINET DISASSEMBLY INSTRUCTIONS

## 1. Disassembly Flowchart

This flowchart indicates the disassembly steps for the cabinet parts, and the CBA in order to gain access to item(s) to be serviced. When reassembling, follow the steps in reverse order. Bend, route and dress the cables as they were.

### Caution !

When removing the CRT, be sure to discharge the Anode Lead of the CRT with the CRT Ground Wire before removing the Anode Cap.

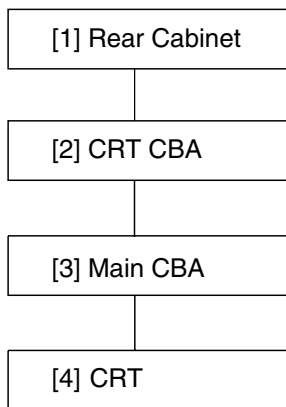

## 2. Disassembly Method

Step/ Loc. No.	Part	Removal		
		Fig. No.	Remove/*unlock/ release/unplug/ unclamp/desolder	Note
[1]	Rear Cabinet	1,2	4(S-1)	1
[2]	CRT CBA	4,5	CN501	2
[3]	Main CBA	3,5	CN571	3
[4]	CRT	4	4(S-2), Anode Cap	4

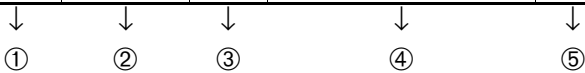

### Note :

- ①. Order of steps in procedure. When reassembling, follow the steps in reverse order. These numbers are also used as the Identification (location) No. of parts in figures.
- ②. Parts to be removed or installed.
- ③. Fig. No. showing procedure of part location
- ④. Identification of part to be removed, unhooked, unlocked, released, unplugged, unclamped, or desoldered.  
S=Screw, P=Spring, L=Locking Tab, CN=Connector, \*=Unhook, Unlock, Release, Unplug, or Desolder  
2(S-2) = two Screws (S-2)
- ⑤. Refer to the following "Reference Notes in the Table."

### Reference Notes in the Table

1. Removal of the Rear Cabinet. Remove screws 4(S-1), then slide the Rear Cabinet backward.
2. Removal of the CRT CBA. Disconnect CN501 then pull the CRT CBA backward.
3. Removal of the Main CBA. Disconnect CN571 on the Main CBA then slide the Main CBA backward.

### Caution !

Discharge the Anode Lead of the CRT with the CRT Ground Wire before removing the Anode Cap.

4. Removal of the CRT. Remove screws 4(S-2) and Anode Cap. then slide the CRT backward.

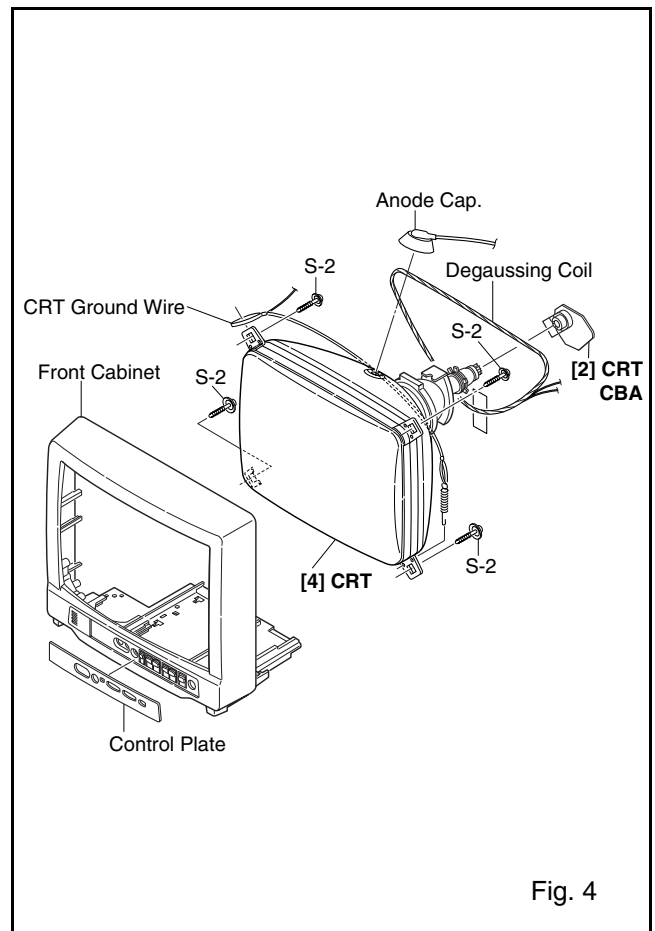
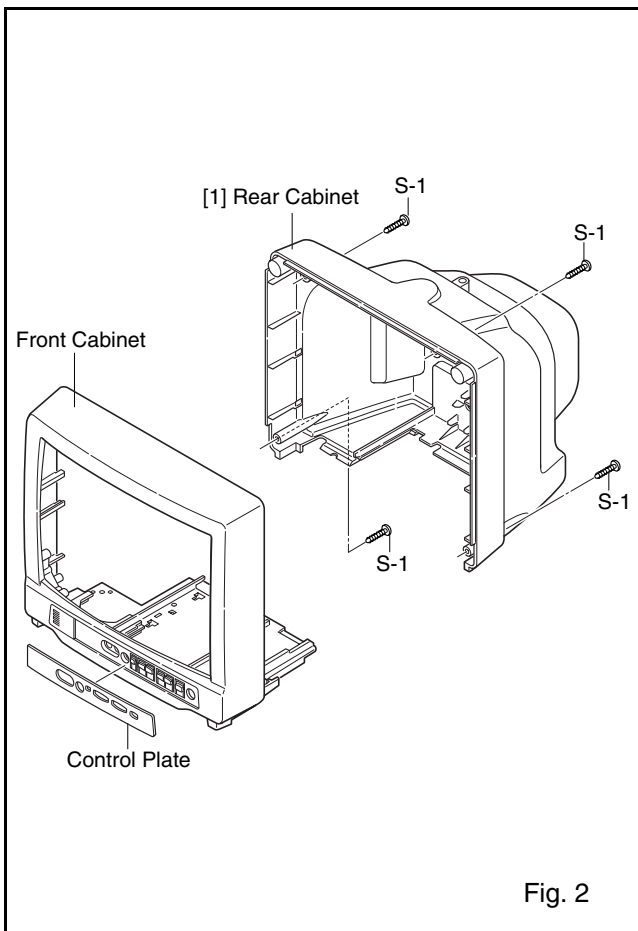
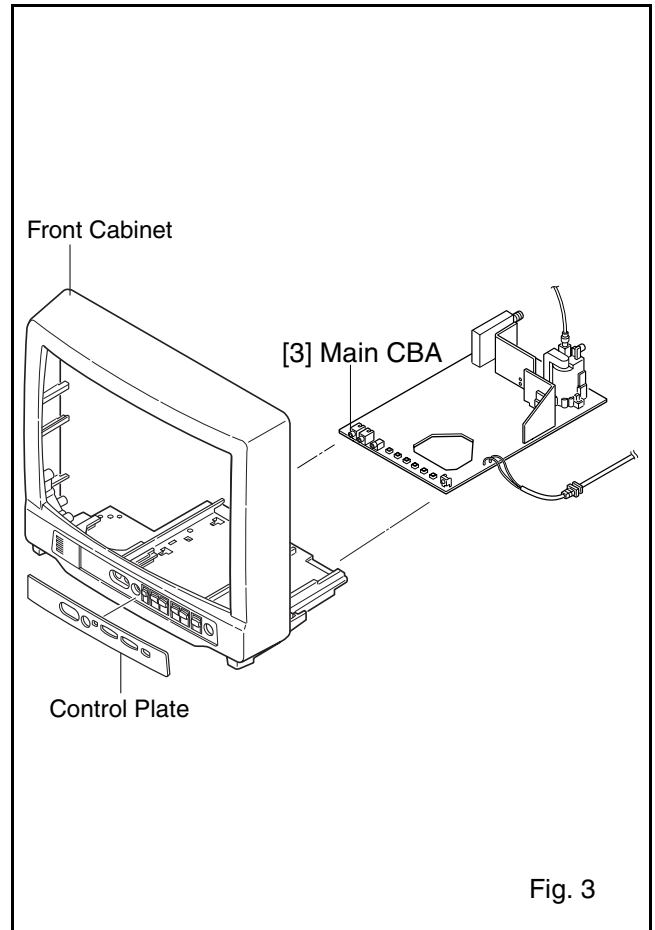
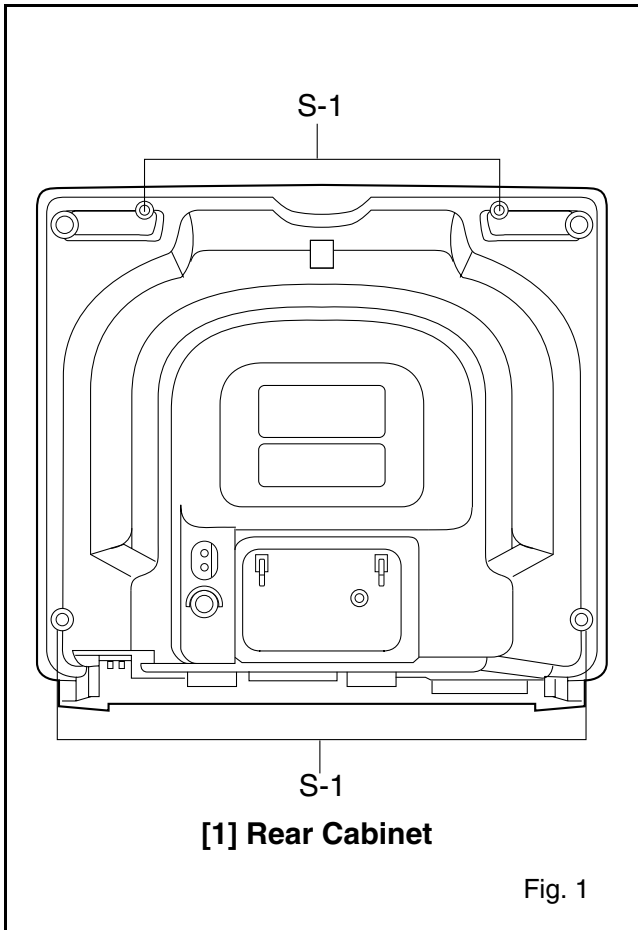

# TV Cable Wiring Diagram

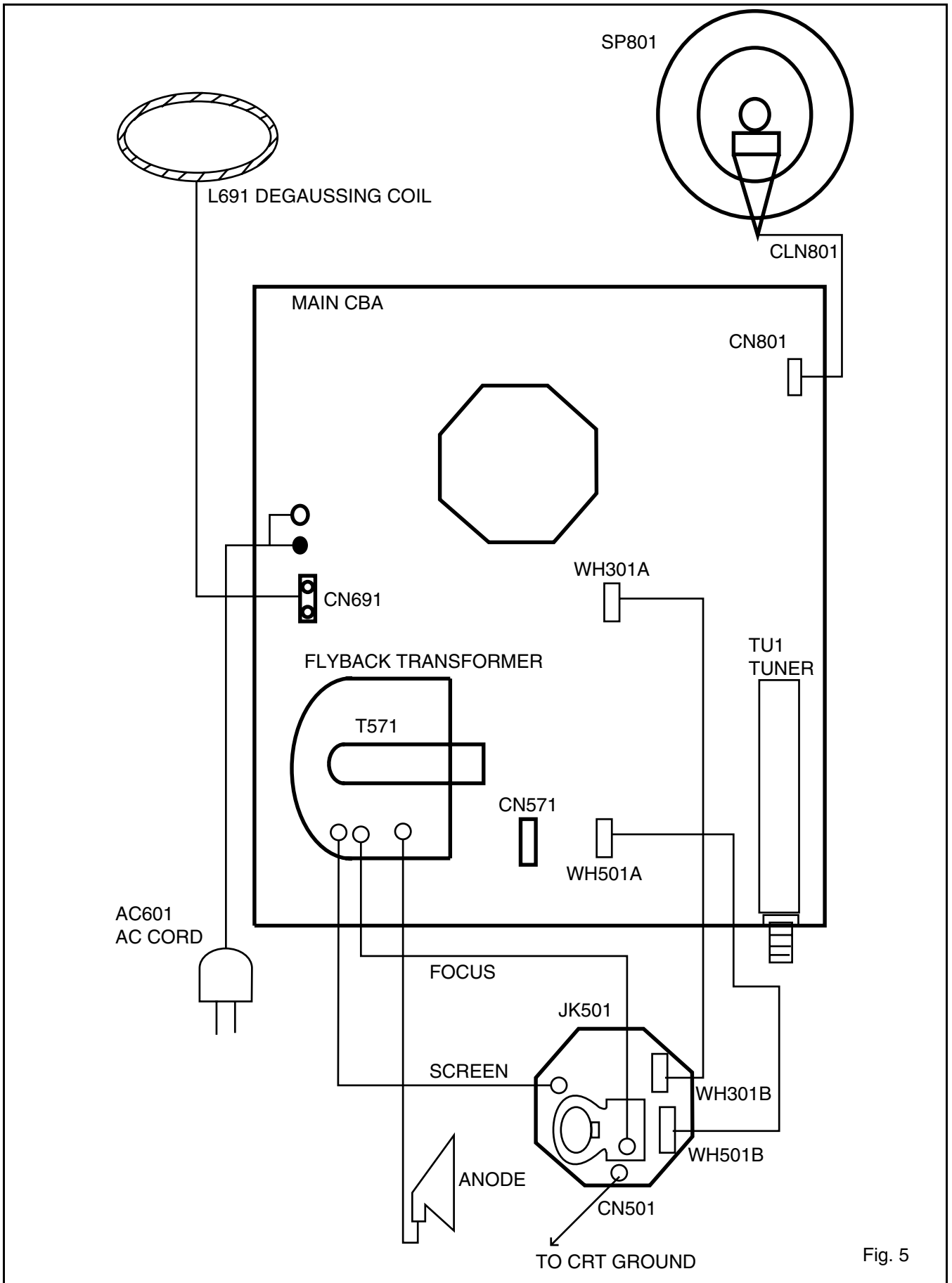

Fig. 5

# ELECTRICAL ADJUSTMENT INSTRUCTIONS

## General Note:

"CBA" is abbreviation for "Circuit Board Assembly".

## NOTE:

Electrical adjustments are required after replacing circuit components and certain mechanical parts. It is important to perform these adjustments only after all repairs and replacements have been completed.

Also, do not attempt these adjustments unless the proper equipment is available.

## Test Equipment Required

1. NTSC Pattern Generator (Color Bar W/White Window, Red Color, Dot Pattern, Gray Scale, Monoscope, Multi-Burst)
2. DC Voltmeter
3. Oscilloscope: Dual-trace with 10:1 probe, V-Range: 0.001~50V/Div, F-Range: DC~AC-60MHz
4. Plastic Tip Driver
5. Remote control unit: Part No. N0121UD or N0134UD
6. DC power supply 13.2V/5A

## How to make Service remote control unit:

1. Prepare normal remote control unit. (Part No. N0121UD or N0134UD) Remove 3 Screws from the back lid. (Fig. 1-1)
2. Added J1 (Jumper Wire) to the remote control CBA. (Fig. 1-2)

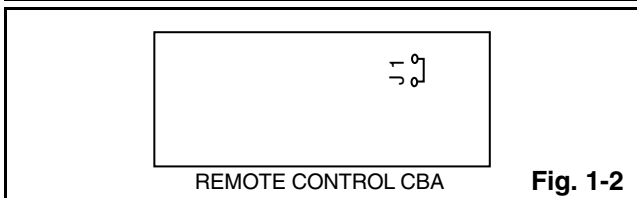
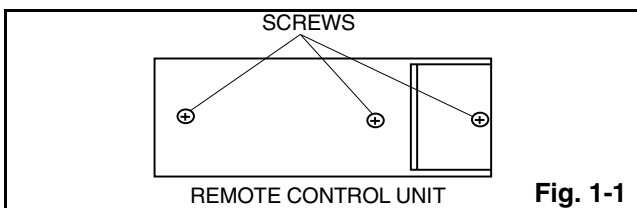

## How to set up the service mode:

### Service mode:

1. Use the service remote control unit.
2. Turn the power on. (Use main power on the TV unit.)

3. Press " SLEEP " button on the service remote control unit. Version of micro computer will display on the CRT. (Ex: 054-0.13)

4. When CPU version is 054-0.13: Check the display on the lower left is "00" and if it is not "00", set it at "00" according to "3-1 FRENCH, ACCESS CODE, VIDEO TONE".

## 1. DC 105V Adjustment

**Purpose:** To obtain correct operation.

**Symptom of Misadjustment:** The picture is dark and the unit does not operate correctly.

Test Point	Adj. Point	Mode	Input
TP601 TP300 (GND)	VR661	---	---
Tape	M. EQ.	Spec.	
---	DC Voltmeter	+105±0.5V DC.	

**Note:** TP601, TP300(GND), VR661 --- Main CBA

1. Connect DC Volt Meter to TP601 and TP300(GND).
2. Adjust VR661 so that the voltage of TP601 becomes +105±0.5V DC.

## 2. Black Stretch Control Adjustment

**Purpose:** To show the fine black color.

**Symptom of Misadjustment:** Black color will not appear correctly.

**Note:** Use Service remote control unit.

1. Enter the Service mode. (See page 5-1)
2. Press " 6 " button on the Service remote control unit. " B-S " is indicated.
3. Press " CH ▲ / ▼ " buttons on the Service remote control unit so that display will change " OFF ", " 0 ", " 1 ", " 2 " and " 3 ". Then choose " B-S OFF ".
4. Press " 6 " button on the Service remote control unit. " B-S\*2 " is indicated.
5. Press " CH ▲ / ▼ " buttons on the Service remote control unit so that display will change " 0 ", " 1 ", " 2 " and " 3 ". Then choose " B-S\*2 0 ".
6. Turn the power off and on again. (Main power button on the TV unit.)

### 3-1. Setting for 7F and FRENCH data Values

#### General

1. Enter the Service mode. (See page 5-1)
2. Press " VOL ▼ " button on the Service remote control unit. Display changes " C/D ", " VCO ", " 7F " and " FRENCH " cyclically when " VOL ▼ " button is pressed.

#### 7F

1. Press " VOL ▼ " button on the Service remote control unit. Then select 7F display.
2. Press " CH ▲ / ▼ " buttons on the Service remote control unit. Then choose 7F=FF.

#### FRENCH

1. Press " VOL ▼ " button on the Service remote control unit. Then select FRENCH display.
2. Press " CH ▲ / ▼ " buttons on the Service remote control unit. Then choose FRENCH=ON.

**ACCESS CODE ---- set to OFF**

VIDEO TONE ---- set to OFF

**Note:** C/D and VCO data values are no need to adjust at this moment.

### 3-2. Setting for CONTRAST, COLOR, TINT, V-TINT and SHARP data Values

#### General

1. Enter the Service mode. (See page 5-1)
2. Press " MENU " button on the Service remote control unit. Display changes " BRIGHT ", " CONTRAST ", " COLOR ", " TINT ", " V-TINT " and " SHARP " cyclically when " MENU " button is pressed.

#### CONTRAST (CNT)

1. Press " MENU " button on the Service remote control unit. Then select " CONTRAST " (CNT) display.
2. Press " CH ▲ / ▼ " buttons on the Service remote control unit so that the value of " CONTRAST " (CNT) becomes 92.

#### COLOR (CLR)

1. Press " MENU " button on the Service remote control unit. Then select " COLOR " (CLR) display.
2. Press " CH ▲ / ▼ " buttons on the Service remote control unit so that the value of " COLOR " (CLR) becomes 56.

#### TINT (TNT)

1. Press " MENU " button on the Service remote control unit. Then select " TINT " (TNT) display.
2. Press " CH ▲ / ▼ " buttons on the Service remote control unit so that the value of " TINT " (TNT) becomes 60.

#### V-TINT (V-TNT)

1. Press " MENU " button on the Service remote control unit. Then select " V-TINT " (V-TNT) display.
2. Press " CH ▲ / ▼ " buttons on the Service remote control unit so that the value of " V-TINT " (V-TNT) becomes 60.

#### SHARP (SHARP)

1. Press " MENU " button on the Service remote control unit. Then select " SHARP " (SHARP) display.
2. Press " CH ▲ / ▼ " buttons on the Service remote control unit and select " SHARP OFF ".

**Note:** BRIGHT data value is no need to adjust at this moment.

## 4. H f<sub>0</sub> Adjustment

**Purpose:** To get correct horizontal frequency.

**Symptom of Misadjustment:** . If H f<sub>0</sub> adjustment is in correct, sqew distortion will appear on the screen.

Test Point	Adj. Point	Mode	Input
TP302	CH ▲ / ▼ button ["H-ADJ"] MODE		----
Tape	M. EQ.	Spec.	
----	Frequency Counter	15.734 kHz±300Hz	

**Note:** TP302 --- Main CBA

Use Service remote control unit.

1. Connect Frequency Counter to TP302 and ground.
2. Set the unit to the VIDEO mode which is located before CH2 and no input is necessary. Enter the Service mode. (See Page 5-1)
3. Operate the unit for at least 20 minutes.
4. Press " 2 " button on the Service remote control unit and select H-ADJ Mode. (By pressing " 2 " button the display will change from TV AGC to H-ADJ)
5. Press " CH ▲ / ▼ " button on the Service remote control unit so that the display will change " 0 " ~ " 7 ". At this moment, Choose display one of them from " 0 " ~ " 7 " when the Frequency Counter shows 15.734 kHz±300Hz or closer.
6. Turn the power off and on again. (Main Power button on the TV unit.)

## 5. VCO Adjustment

**Purpose:** To operate VCO correctly.

**Symptom of Misadjustment:** VCO does not work correctly and/or synchronization is faulty.

Test Point	Adj. Point	Mode	Input
---	---		No signal
Tape	M. EQ.	Spec.	
---	---	---	

**Note:** Use service remote control unit.

1. Disconnect the RF input and set the unit to Channel 4.
2. Enter the Service mode. (See Page 5-1)
3. Press " 3 " button on the Service remote control unit. The Auto VCO adjustment is started.
4. If the display color is changed from red to green, This adjustment is done.
5. Turn the Power off and on again. (Main power button on the TV unit.)

## 6. AGC Adjustment

**Purpose:** Set AGC (Auto Gain Control) Level.

**Symptom of Misadjustment:** AGC does not synchronize correctly when RF input level is too weak and picture distortion may occur if it is too strong.

Test Point	Adj. Point	Mode	Input
TP301	CH ▲ / ▼ buttons	RF	Color Bar 67.25MHz 60dB $\mu$ V
Tape	M. EQ.	Spec.	
---	Pattern Generator DC Volt Meter	+2.5 $\pm$ 0.1VDC or +2.8 $\pm$ 0.1VDC by Tuner Type.	

**Notes:** TP301 --- Main CBA

Use Service remote control unit.

1. Enter the Service mode. (See Page 5-1) Then press number " 2 " button on the Service remote control unit.
2. Receive the Color Bar signal for channel 4 (67.25MHz). (RF Input Level: 60dB $\mu$ V)
3. Press " CH ▲ / ▼ " buttons so that the voltage of TP301 becomes +2.5 $\pm$ 0.1V DC. If the tuner is used TEDH9-300A. (Tuner type number)
4. Press " CH ▲ / ▼ " buttons so that the voltage of TP301 becomes +2.8 $\pm$ 0.1V DC. If the tuner is used B8095AD. (Tuner type number)
5. Turn the Power off and on again. (Main power button on the TV unit.)

## 7. Black Level Adjustment

**Purpose:** Set Sub-bright Level

**Symptom of Misadjustment:** If Sub-brightness is incorrect, Proper brightness can not be obtained by adjusting the Brightness Control.

**Note:** TP502, TP501 (GND) --- CRT CBA

1. Enter the Service mode. (See page 5-1).
2. Press " MENU " button on the Service remote control unit and select " BRT " mode. (Display changes " BRT ", " CNT ", " CLR " and " TNT " cyclically when MENU button is pressed).
3. Press " CH ▲ / ▼ " buttons on the Service remote control unit so that the value of " BRT " becomes 128.
4. Turn the power off and on again. (Main power button on the TV unit.)

## 8. C-Trap Adjustment

**Purpose:** To get minimum leakage of the color signal carrier.

**Symptom of Misadjustment:** If C- Trap Adjustment is incorrect, stripes will appear on the screen.

Test Point	Adj. Point	Mode	Input
TP502 (Blue) TP501 (GND)	CH ▲ / ▼ buttons	RF	Color Bar
Tape	M. EQ.	Spec.	
----	Oscilloscope	----	

**Note:** TP502, TP501 --- CRT CBA

Use Service remote control unit.

1. Connect Oscilloscope to TP502 and TP501 (GND).
2. Enter the Service mode. (See Page 5-1) Receive color bar signal from RF Input.
3. Press " 0 " button on the Service remote control unit and select C-TRP Mode.
4. Press " CH ▲ / ▼ " buttons on the Service remote control unit so that the display will change " 0 ", " 1 ", " 2 " and " 3 ". Choose display " 0 ", " 1 ", " 2 " or " 3 " when B-Out (3.58MHz) value becomes minimum on the oscilloscope reading.
5. Turn the power off and on again. (Main power button on the TV unit.)



## 9. V. Size Adjustment

**Purpose:** To obtain correct vertical width of screen image.

**Symptom of Misadjustment:** If V. Size is incorrect, vertical size of image on the screen may not be properly displayed.

Test Point	Adj. Point	Mode	Input
---	Screen Control CH ▲ / ▼ buttons [ V-S ] Mode	RF	Monoscope
<b>Tape</b>	<b>M. EQ.</b>	<b>Spec.</b>	
---	Monoscope	90±5%	

**Note:** Use service remote control unit.

1. Operate the unit for at least 20 minutes.
2. Enter the Service mode. (See page 5-1)
3. Receive the Monoscope Pattern.
4. Press " 9 " button on the Service remote control unit and select " V-S " mode. (Display changes " V-S " and " V-P " cyclically when " 9 " button is pressed).
5. Press " CH ▲ / ▼ " buttons on the Service remote control unit so that the monoscope pattern will be 90±5% of display size and the circle is round.
6. Turn the power off and on again. (Main power button on the TV unit.)

## 10. V. Position Adjustment

**Purpose:** To obtain correct vertical width of screen image.

**Symptom of misadjustment:** If V. Position is incorrect, vertical height of image on the screen may not be properly displayed.

Test Point	Adj. Point	Mode	Input
---	Screen Control CH ▲ / ▼ buttons [ V-P ] Mode	RF	Monoscope
<b>Tape</b>	<b>M. EQ.</b>	<b>Spec.</b>	
---	Monoscope	90±5%	

**Note:** Use Service remote control unit

1. Operate the unit for at least 20 minutes.
2. Enter the Service Mode. (See page 5-1)
3. Receive the Monoscope Pattern.
4. Press " 9 " button on the Service remote control unit and select " V-P " mode. (Display change " V-S " and " V-P " cyclically when " 9 " button is pressed).
5. Press " CH ▲ / ▼ " buttons on the Service remote control unit so that the top and bottom of the monoscope pattern will be equal of each other.
6. Turn the Power off and on again. (Main power button on the TV unit.)

## 11. H. Position Adjustment

**Purpose:** To obtain correct horizontal position of screen image.

**Symptom of Misadjustment:** If H. Position is incorrect, horizontal position of image on the screen may not be properly displayed.

Test Point	Adj. Point	Mode	Input
---	Screen Control CH ▲ / ▼ buttons [ H-P ] Mode	RF	Monoscope
<b>Tape</b>	<b>M. EQ.</b>	<b>Spec.</b>	
---	Monoscope	90±5%	

**Note:** Use Service remote control unit

1. Operate the unit for at least 20 minutes.
2. Enter the Service mode. (See page 5-1)
3. Receive the Monoscope Pattern.
4. Press " 8 " button on the remote control unit and select " H-P " mode.
5. Press " CH ▲ / ▼ " buttons on the Service remote control unit so that the monoscope pattern will be 90±5% of display size and the circle is round.
6. Turn the Power off and on again. (Main power button on the TV unit.)

## 12. Cut-off Adjustment

**Purpose:** To adjust the beam current of R, G, B, and screen voltage.

**Symptom of Misadjustment:** White color may be reddish, greenish or bluish.

Test Point	Adj. Point	Mode	Input
---	Screen-Control CH ▲ / ▼ buttons	RF	Black Raster
Tape	M. EQ.	Spec.	
---	Pattern Generator	See Reference Notes below.	

**Figure**

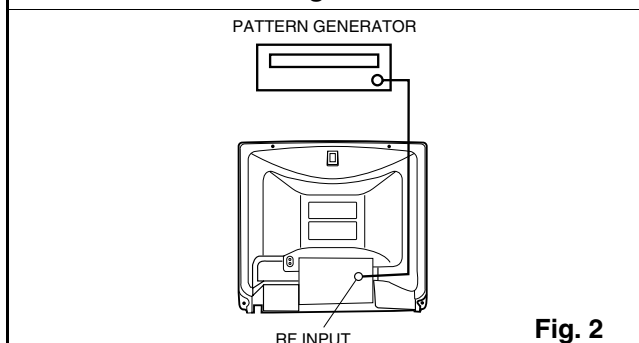

**Fig. 2**

**Note:** Screen Control FBT --- Main CBA

F.B.T= Fly Back Transformer

Use Service remote control unit

1. Degauss the CRT and allow CRT to operate for 20 minutes before starting the alignment.
2. Input the Black Raster Signal from RF Input.
3. Enter the Service mode. (See page 5-1)
4. Press " VOL ▼ " button on the Service remote control unit and select " C/D " mode. (Display changes " C/D ", "VCO ", " 7F ", " FRENCH ", "ACCESS CODE" and "VIDEO TONE" cyclically when " VOL ▼ " button is pressed.) then press " 1 ". The display will momentarily show " CUT OFF R " (R= Red). Now there should be a horizontal line across the center of the picture tube. If needed gradually turn the screen control on the flyback, clockwise until the horizontal line appears. Adjust the Red Cut off by pressing the " CH ▲ / ▼ " buttons. Proceed to Step 5 when the Red Cut off adjustment is done.
5. Press the " 2 " button. The display will momentarily show " CUT OFF G " (G=Green). Adjust the Green Cut off by pressing the " CH ▲ / ▼ " buttons. Proceed to step 6 when the Green Cut off adjustment is done.
6. Press the " 3 " button. The display will momentarily show " CUT OFF B " (B=Blue). Adjust the Blue cut off by pressing the " CH ▲ / ▼ " buttons. When done with steps 4, 5 and 6 the horizontal line should be pure white if not, then attempt the Cut off adjustment again.

## 13. White Balance Adjustment

**Purpose:** To mix red, green and blue beams correctly for pure white.

**Symptom of Misadjustment:** White becomes bluish or reddish.

Test Point	Adj. Point	Mode	Input
Screen	CH ▲ / ▼ buttons	RF	White Raster (APL 100%)
Tape	M. EQ.	Spec.	
	Pattern Generator, Color analyzer	See below	

**Figure**

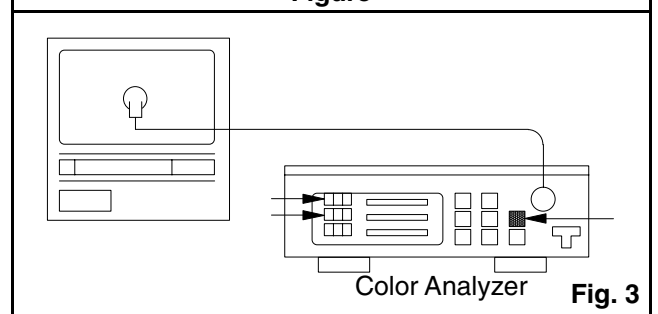

**Fig. 3**

**Note:** Use Service remote control unit

1. Operate the unit more than 20 minutes.
  2. Face the unit to east. Degauss the CRT using Degaussing Coil.
  3. Input the White Raster (APL 100%).
  4. Set the color analyzer to the CHROMA mode and after zero point calibration, bring the optical receptor to the center on the tube surface (CRT).
  5. Enter the Service mode . Press " VOL ▼ " button on the Service remote control unit and select " C/D " mode. (Display changes " C/D ", "VCO ", " 7F " and " FRENCH ", "ACCESS CODE" and "VIDEO TONE" cyclically when " VOL ▼ " button is pressed.) then Press No. 8 button on the Service remote control Unit.
  6. Press No. 4 button on the service remote control unit for Red adjustment. Press NO. 5 button on the Service remote control unit for Blue adjustment.
  7. In each color mode, Press " CH ▲ / ▼ " button to adjust the values of color.
  8. Adjusting Red and Blue color so that the temperature becomes 9200K (x : 286 / y : 294) ±3%.
  9. At this time, Re-check that Horizontal line is white. If not, Re-adjust Cut-off Adjustment until the Horizontal Line becomes pure white.
  10. Turn off and on again to return to normal mode. Receive APL 100% white signal and Check Chroma temperatures become 9200K (x : 286 / y : 294) ±3%.
- Note:** Confirm that Cut Off Adj. is correct after this adjustment, and attempt Cut Off Adj. if needed.

## 14. Sub-Brightness Adjustment

**Purpose:** To get proper brightness.

**Symptom of Misadjustment:** If Sub-Brightness is incorrect, proper brightness cannot be obtained by adjusting the Brightness Control.

Test Point	Adj. Point	Mode	Input
---	CH ▲ / ▼ buttons	RF	IQW
Tape	M. EQ.	Spec.	
---	Pattern Generator	See below	

**Figure**

**Note:** IQW Setup level --- 7.5 IRE  
Use Service remote control unit

1. Enter the Service mode. (See page 5-1)  
Then input IQW signal from RF Input.
2. Press "MENU" button on the Service remote control unit and Select "BRT" mode. (Display changes "BRT", "CNT", "CLR", and "TNT" cyclically when MENU button is pressed). Press "CH ▲ / ▼" buttons so that the bar is just visible (See above figure).
3. Turn the power off and on again. (Main power button on the TV unit.)

## 15. Focus Adjustment

**Purpose:** Set the optimum Focus.

**Symptom of Misadjustment:** If Focus Adjustment is incorrect, blurred images are shown on the display.

Test Point	Adj. Point	Mode	Input
---	Focus Control	---	Monoscope
Tape	M. EQ.	Spec.	
---	Pattern Generator	See below.	

**Note:** FocusVR(FBT)—MainCBA FBT=FlyBackTransformer

1. Operate the unit more than 30 minutes
2. Face the unit to the East and Degauss the CRT using Degaussing Coil.
3. Input the Monoscope Pattern.
4. Adjust the Focus Control on the FBT to obtain clear picture.

The following 2 adjustments normally are not attempted in the field. Only when replacing the CRT then adjust as a preparation.

## 16. Purity Adjustment

**Purpose:** To obtain pure color.

**Symptom of Misadjustment:** If Color Purity Adjustment is incorrect, large areas of color may not be properly displayed.

Test Point	Adj. Point	Mode	Input
---	Deflection Yoke Purity Magnet	---	Red Color
Tape	M. EQ.	Spec.	
---	Pattern Generator	See below.	

**Figure**

1. Set the unit facing east.
2. Operate the unit for over 30 minutes before adjusting.
3. Fully degauss the unit using an external degaussing coil.
4. Loosen the screw on the Deflection Yoke Clamper and pull the Deflection Yoke back away from the screen. (See Fig. 6)
5. Loosen the Ring Lock and adjust the Purity Magnets so that a red field is obtained at the center of the screen. Tighten Ring Lock. (See Fig. 5,6)
6. Slowly push the Deflection Yoke toward bell of CRT and set it where a uniform red field is obtained.
7. Tighten the clamp screw on the Deflection Yoke.

# 17. Convergence Adjustment

**Purpose:** To obtain proper convergence of red, green and blue beams.

**Symptom of Misadjustment:** If Convergence Adjustment is incorrect, the edge of white letters may have color edges.

Test Point	Adj. Point	Mode	Input
---	C.P. Magnet (RB), C.P. Magnet (RB-G), Deflection Yoke	---	Dot Pattern or Crosshatch
Tape	M. EQ.	Spec.	
---	Pattern Generator	See below.	

### Figures

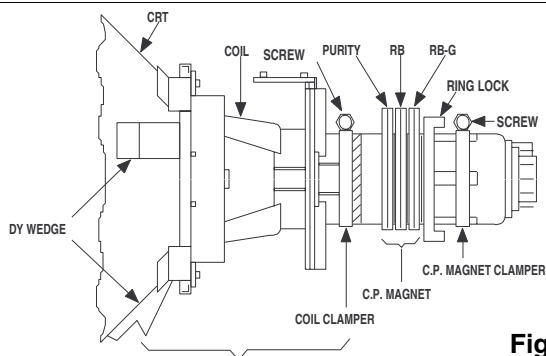

**Fig. 6**

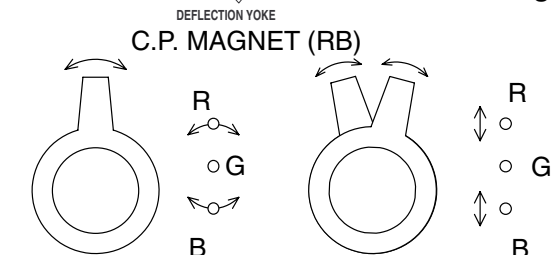

**Fig. 7**

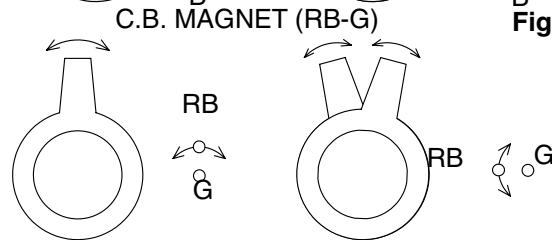
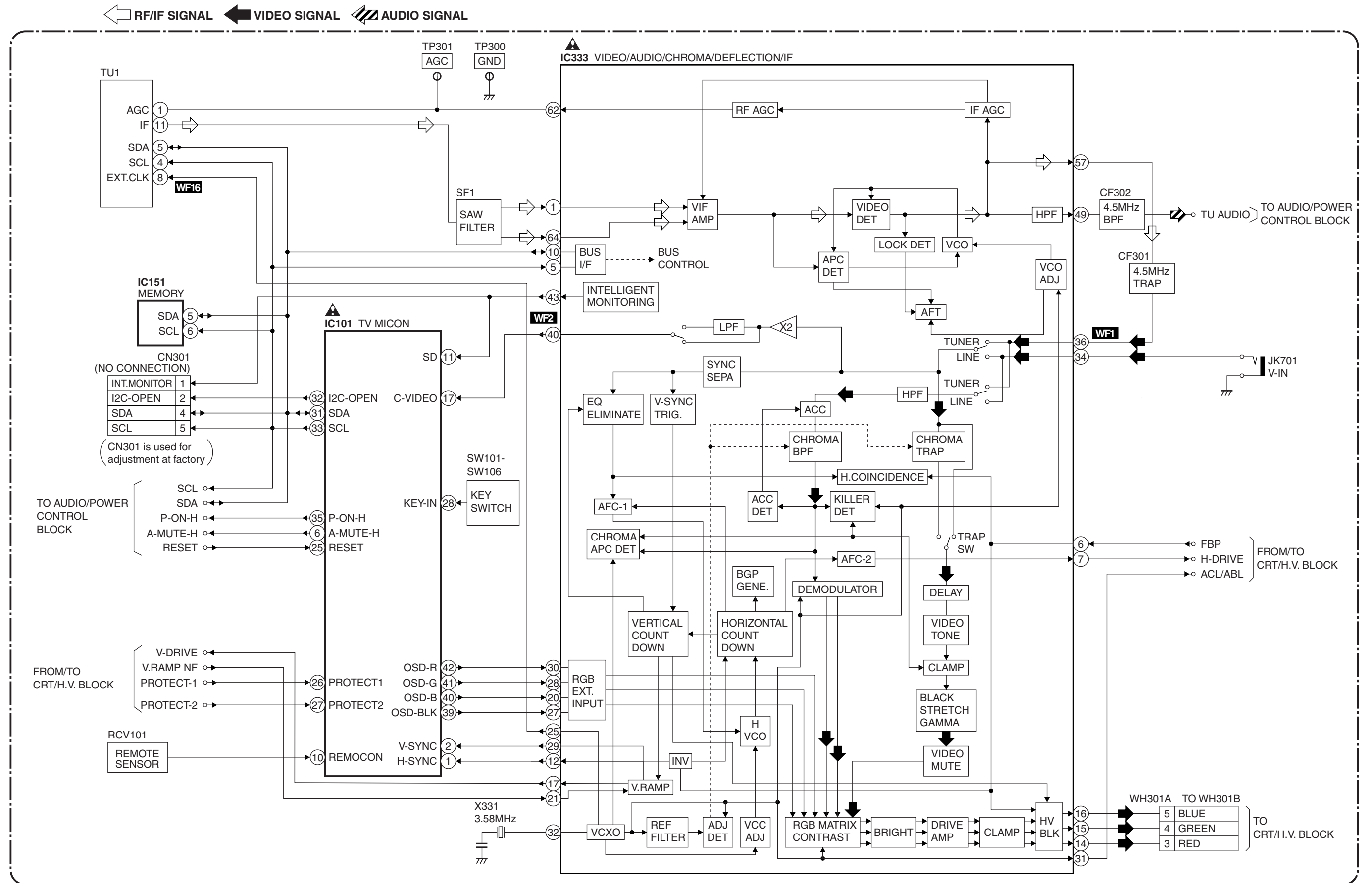

**Fig. 8**

1. Loosen the Ring Lock and align red with blue dots or Crosshatch at the center of the screen by rotating (RB) C.P. Magnets. (See Fig. 7)
2. Align red / blue with green dots at the center of the screen by rotating (RB-G) C.P. Magnet. (See Fig. 8)
3. Fix the C.P. Magnets by tightening the Ring Lock.
4. Remove the DY Wedges and slightly tilt the Deflection Yoke horizontally and vertically to obtain the best overall convergence.
5. Fix the Deflection Yoke by carefully inserting the DY Wedges between CRT and Deflection Yoke.

# BLOCK DIAGRAMS

## IF/Video/System Control Block Diagram



# Audio/Power Control Block Diagram

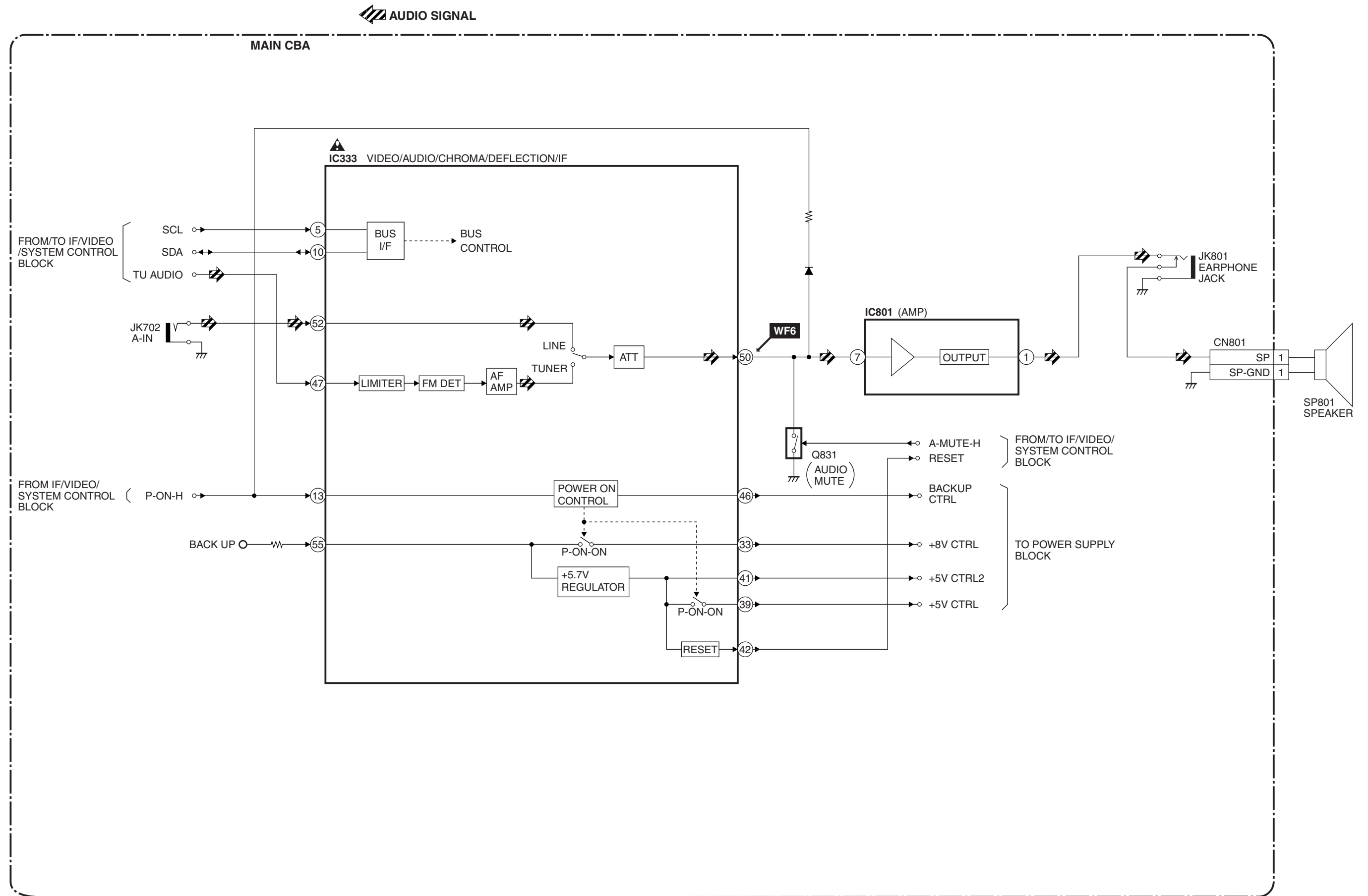

# CRT/H.V. Block Diagram

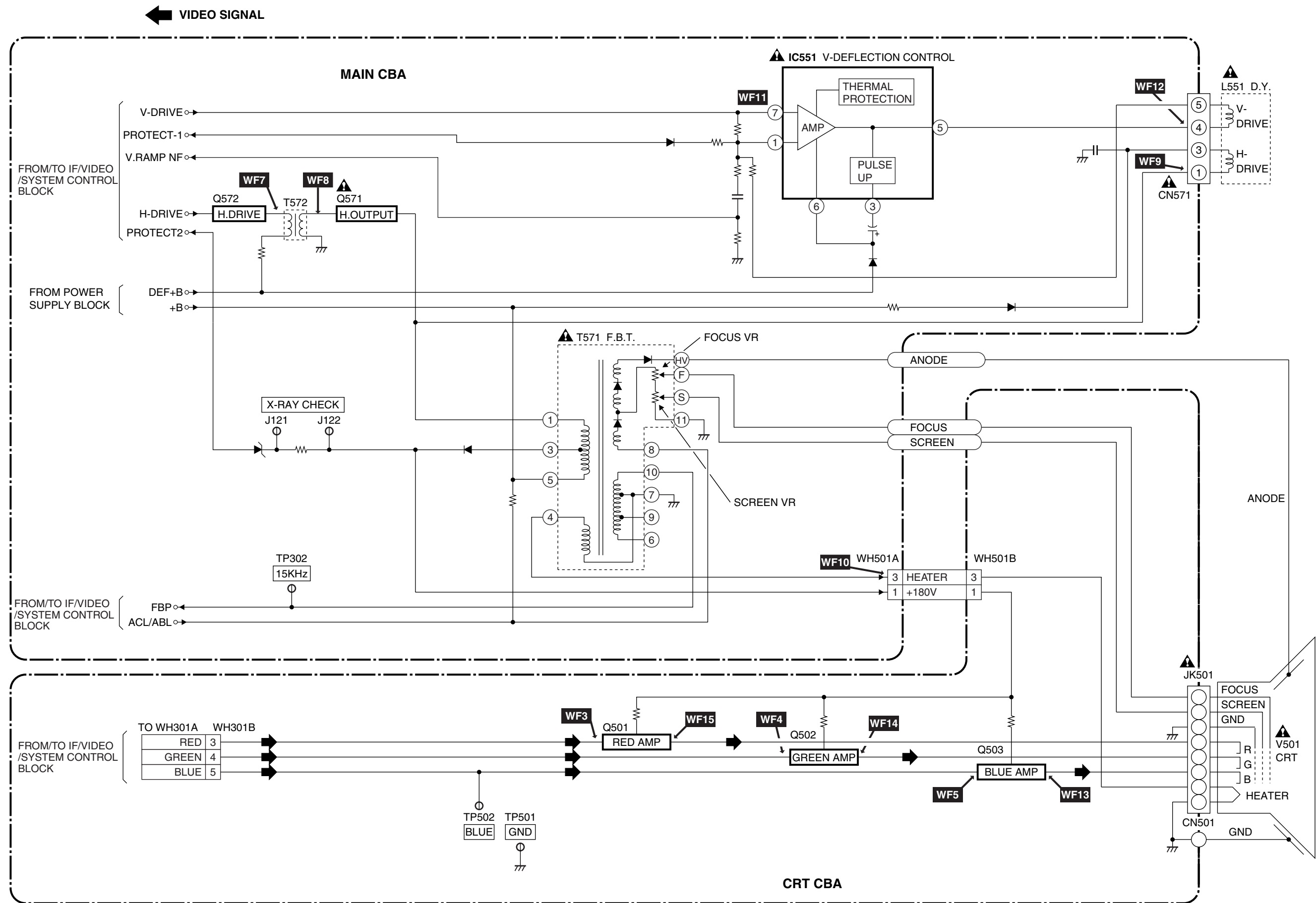

# Power Supply Block Diagram

**CAUTION !**

Fixed voltage power supply circuit is used in this unit.  
If Main Fuse (F601) is blown, check to see that all components in the power supply circuit are not defective before you connect the AC plug to the AC power supply.  
Otherwise it may cause some components in the power supply circuit to fail.

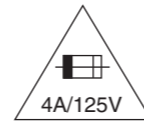

**CAUTION**

FOR CONTINUED PROTECTION AGAINST FIRE HAZARD,  
REPLACE ONLY WITH THE SAME TYPE FUSE.  
ATTENTION : POUR UNE PROTECTION CONTINUE LES RISQUES  
D'INCELE N'UTILISER QUE DES FUSIBLE DE MEME TYPE.  
**RISK OF FIRE-REPLACE FUSE AS MARKED.**

"This symbol means fast operating fuse."  
"Ce symbole représente un fusible à fusion rapide."

**NOTE :**

The voltage for parts in hot circuit is measured using hot GND as a common terminal.

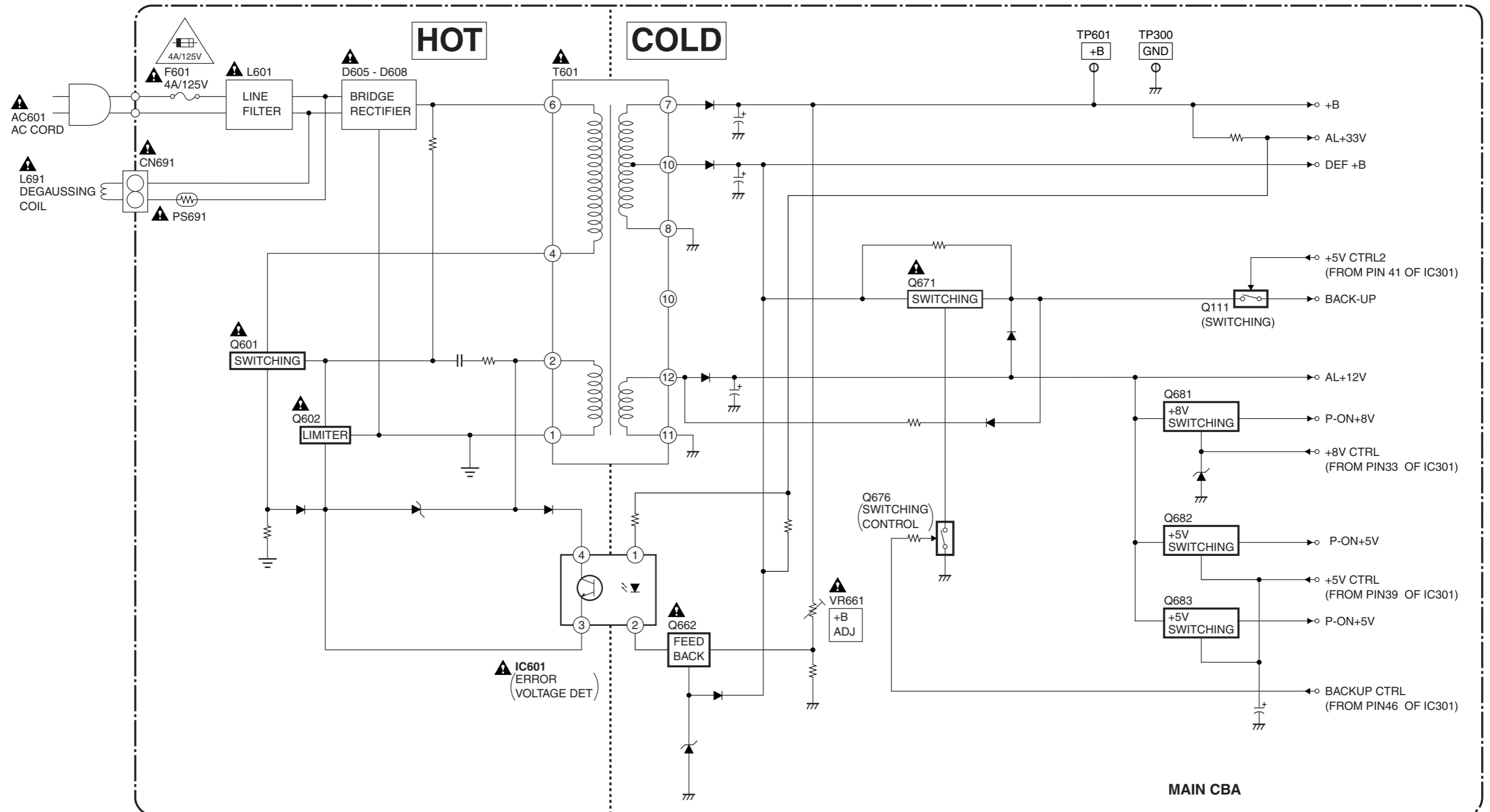



# SCHEMATIC DIAGRAMS / CBA'S AND TEST POINTS

## Standard Notes

Many electrical and mechanical parts in this chassis have special characteristics. These characteristics often pass unnoticed and the protection afforded by them cannot necessarily be obtained by using replacement components rated for higher voltage, wattage, etc. Replacement parts that have these special safety characteristics are identified in this manual and its supplements; electrical components having such features are identified by the mark "▲" in the schematic diagram and the parts list. Before replacing any of these components, read the parts list in this manual carefully. The use of substitute replacement parts that do not have the same safety characteristics as specified in the parts list may create shock, fire, or other hazards.

### Note:

1. Do not use the part number shown on these drawings for ordering. The correct part number is shown in the parts list, and may be slightly different or amended since these drawings were prepared.
2. All resistance values are indicated in ohms ( $K=10^3$ ,  $M=10^6$ ).
3. Resistor wattages are 1/4W or 1/6W unless otherwise specified.
4. All capacitance values are indicated in  $\mu F$  ( $P=10^{-6}\mu F$ ).
5. All voltages are DC voltages unless otherwise specified.

### Note of Capacitors:

ML --- Mylar Cap.    PP --- Metalized Film Cap.    SC --- Semiconductor Cap.    L --- Low Leakage type

### Temperature Characteristics of Capacitors are noted with the following:

B ---  $\pm 10\%$     CH ---  $0 \pm 60 \text{ppm}/^\circ\text{C}$     SL ---  $+350 \sim -1000 \text{ppm}/^\circ\text{C}$

### Tolerance of Capacitors are noted with the following:

Z ---  $+80 \sim -20\%$

### Note of Resistors:

CEM --- Cement Res.    MTL --- Metal Res.    F --- Fuse Res.

Capacitors and transistors are represented by the following symbols.

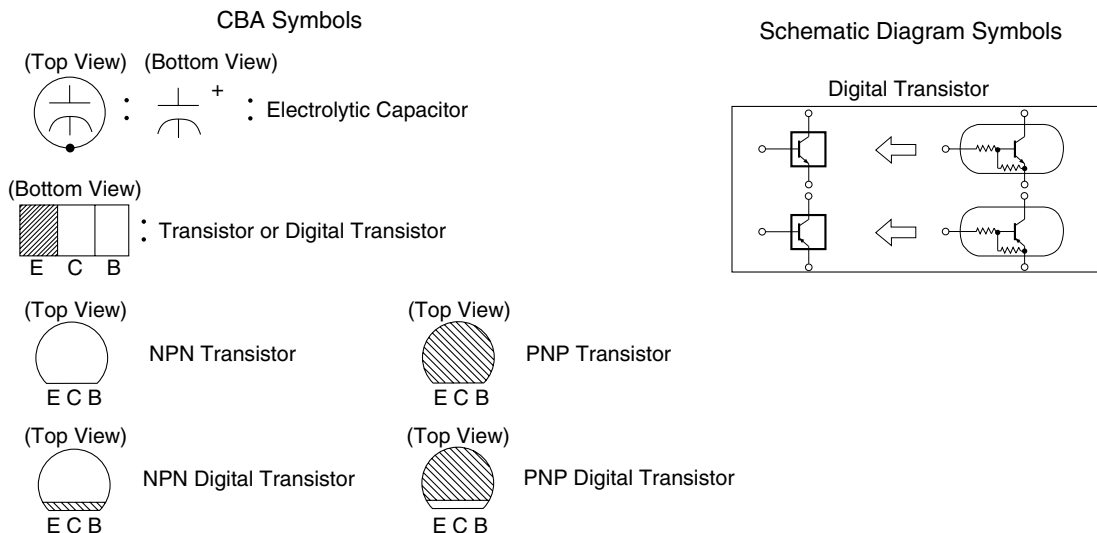

**LILIST OF CAUTION, NOTES, AND SYMBOLS USED IN THE SCHEMATIC DIAGRAMS ON THE FOLLOWING PAGES:**

1. **CAUTION:** FOR CONTINUED PROTECTION AGAINST FIRE HAZARD, REPLACE ONLY WITH THE SAME TYPE FUSE. ATTENTION: POUR UNE PROTECTION CONTINUE LES RISQUES D'INCELE N'UTILISER QUE DES FUSIBLE DE MEMO TYPE.

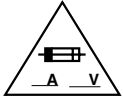

RISK OF FIRE-REPLACE FUSE AS MARKED.

2. **CAUTION:**

Fixed Voltage (or Auto voltage selectable) power supply circuit is used in this unit. If Main Fuse (F001) is blown, first check to see that all components in the power supply circuit are not defective before you connect the AC plug to the AC power supply. Otherwise it may cause some components in the power supply circuit to fail.

3. **Note:**

- (1) Do not use the part number shown on the drawings for ordering. The correct part number is shown in the parts list, and may be slightly different or amended since the drawings were prepared.
- (2) To maintain original function and reliability of repaired units, use only original replacement parts which are listed with their part numbers in the parts list section of the service manual.

4. Wire Connectors

- (1) Prefix symbol "CN" means "connector" (can disconnect and reconnect).
- (2) Prefix symbol "CL" means "wire-solder holes of the PCB" (wire is soldered directly).

5. Note: Mark "•" is a leadless (chip) component.

6. Voltage indications on the schematics are as shown below:  
Plug the TV power cord into a standard AC outlet.

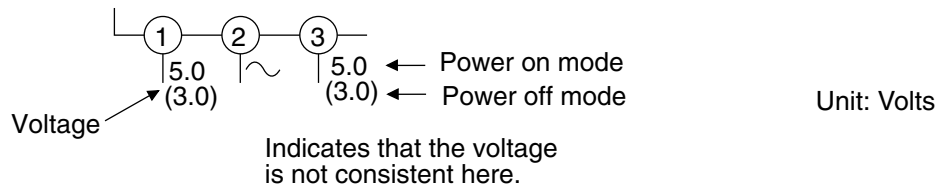

7. How to read converged lines

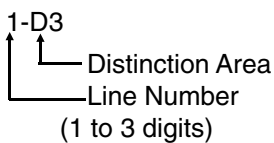

Examples:

- 1. "1-D3" means that line number "1" goes to area "D3".
- 2. "1-B1" means that line number "1" goes to area "B1".

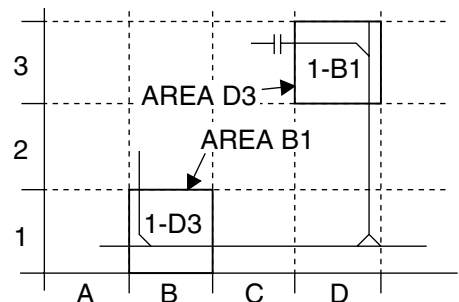

8. Test Point Information

- ⊙ : Indicates a test point with a jumper wire across a hole in the PCB.
- : Used to indicate a test point with a component lead on foil side.
- ⊘ : Used to indicate a test point with no test pin.
- : Used to indicate a test point with a test pin.

Main 1/2 Schematic Diagram

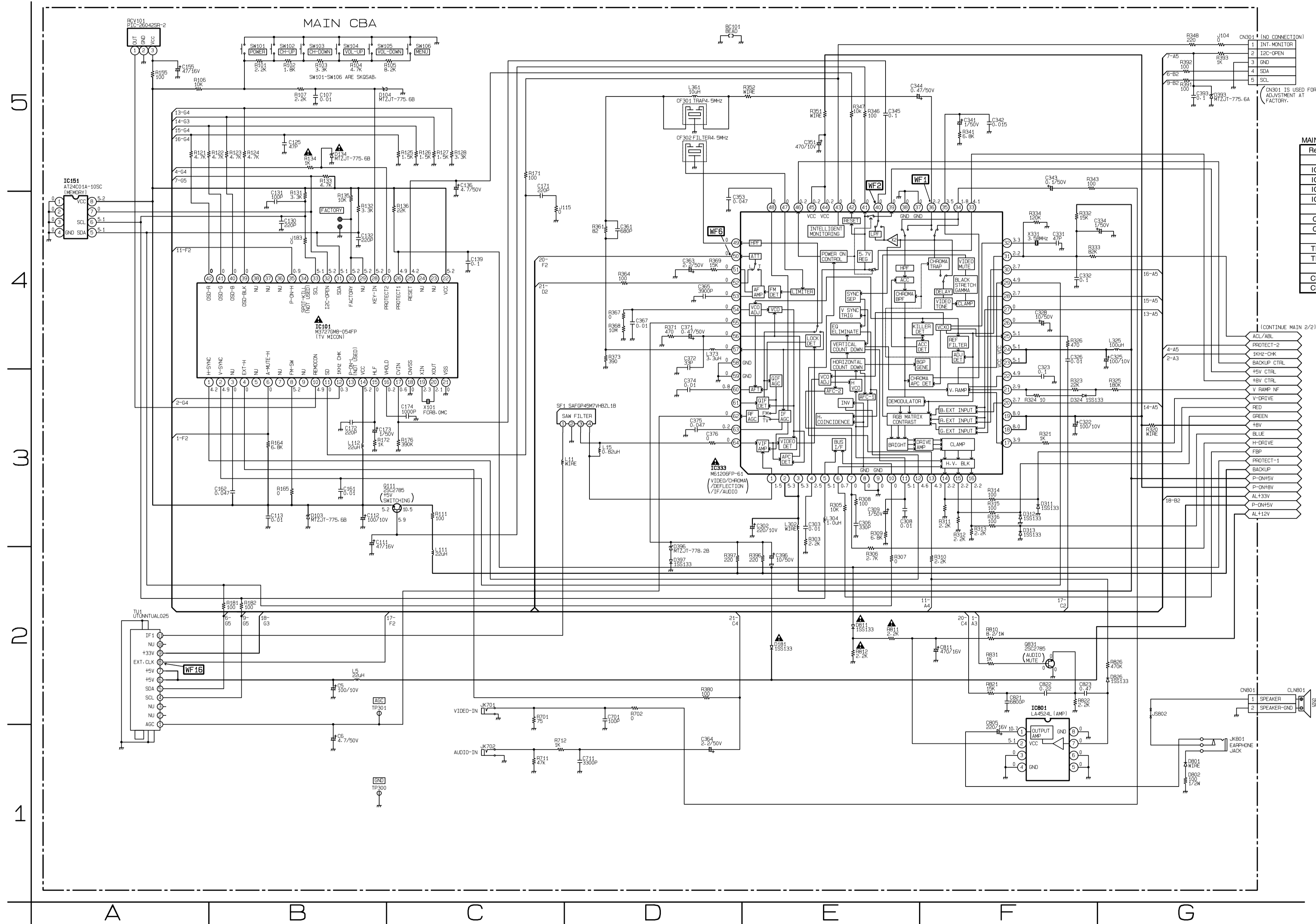

MAIN 1/2		
Ref No.	Position	ICS
IC101	B-4	
IC151	A-5	
IC333	D-3	
IC801	F-2	
TRANSISTORS		
Q111	C-3	
Q831	F-2	
TEST POINTS		
TP300	B-1	
TP301	B-2	
CONNECTORS		
CN301	G-5	
CN801	G-2	

A5	B5	C5	D5	E5	F5	G5
A4	B4	C4	D4	E4	F4	G4
A3	B3	C3	D3	E3	F3	G3
A2	B2	C2	D2	E2	F2	G2
A1	B1	C1	D1	E1	F1	G1

--- IF SIGNAL  
— VIDEO SIGNAL  
◀ AUDIO SIGNAL

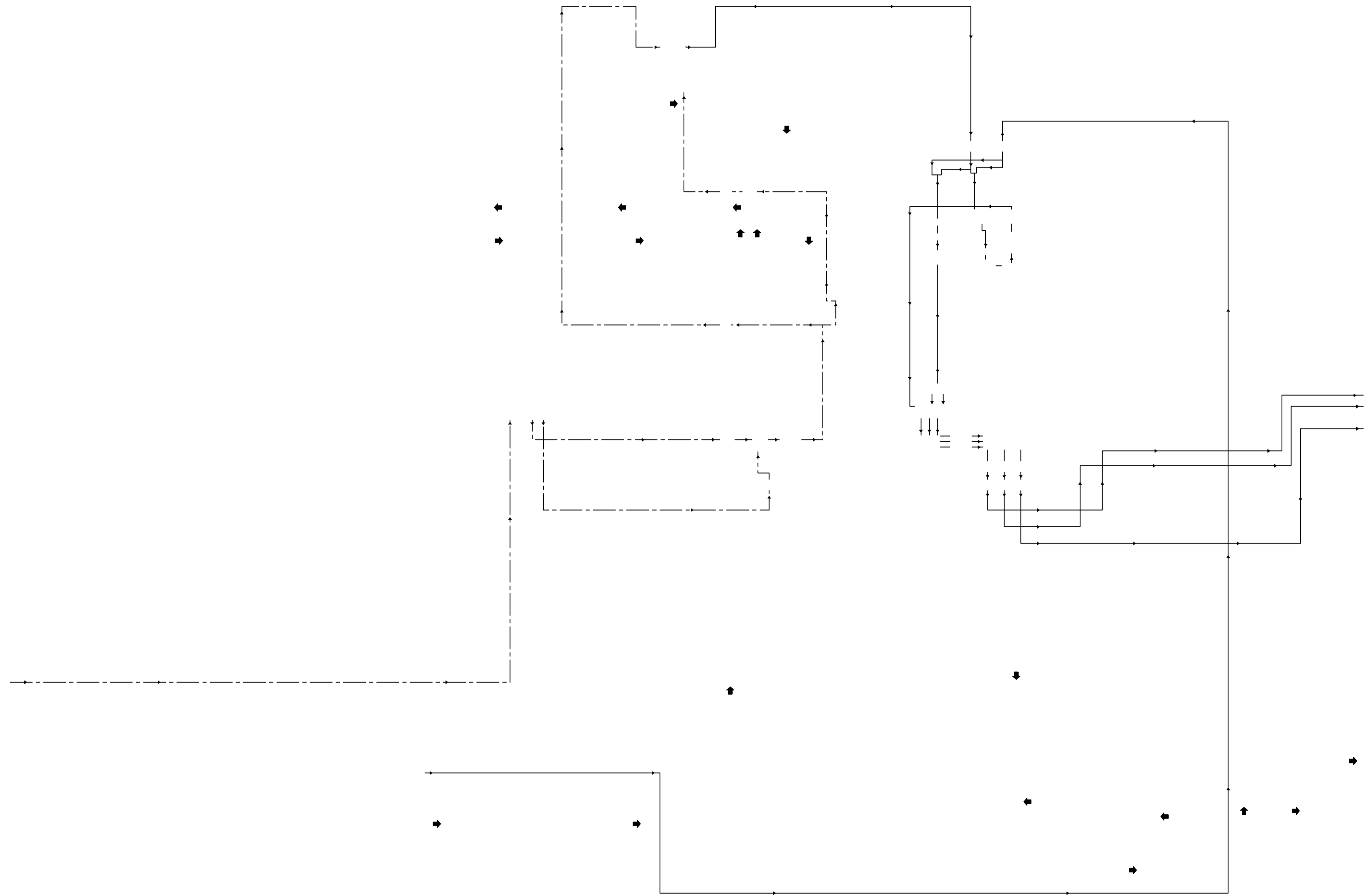

**Main 2/2 & CRT Schematic Diagram**

**CAUTION !**  
Fixed voltage power supply circuit is used in this unit.  
If Main Fuse (F601) is blown, check to see that all components in the power supply circuit are not defective before you connect the AC plug to the AC power supply. Otherwise it may cause some components in the power supply circuit to fail.

**CAUTION**  
FOR CONTINUED PROTECTION AGAINST FIRE HAZARD,  
REPLACE ONLY WITH THE SAME TYPE FUSE.  
ATTENTION : POUR UNE PROTECTION CONTINUE LES RISQUES  
D'INCENDIE N'UTILISER QUE DES FUSIBLES DE MEMO TYPE.  
**RISK OF FIRE-REPLACE FUSE AS MARKED.**  
\*This symbol means fast operating fuse.\*  
\*Ce symbole représente un fusible à fusion rapide.\*

**BECAUSE A HOT CHASSIS GROUND IS PRESENT IN THE POWER SUPPLY CIRCUIT, AN ISOLATION TRANSFORMER MUST BE USED. ALSO, IN ORDER TO HAVE THE ABILITY TO INCREASE THE INPUT SLOWLY, WHEN TROUBLESHOOTING THIS TYPE POWER SUPPLY CIRCUIT, A VARIABLE ISOLATION TRANSFORMER IS REQUIRED.**

**NOTE :**  
The voltage for parts in hot circuit is measured using hot GND as a common terminal.

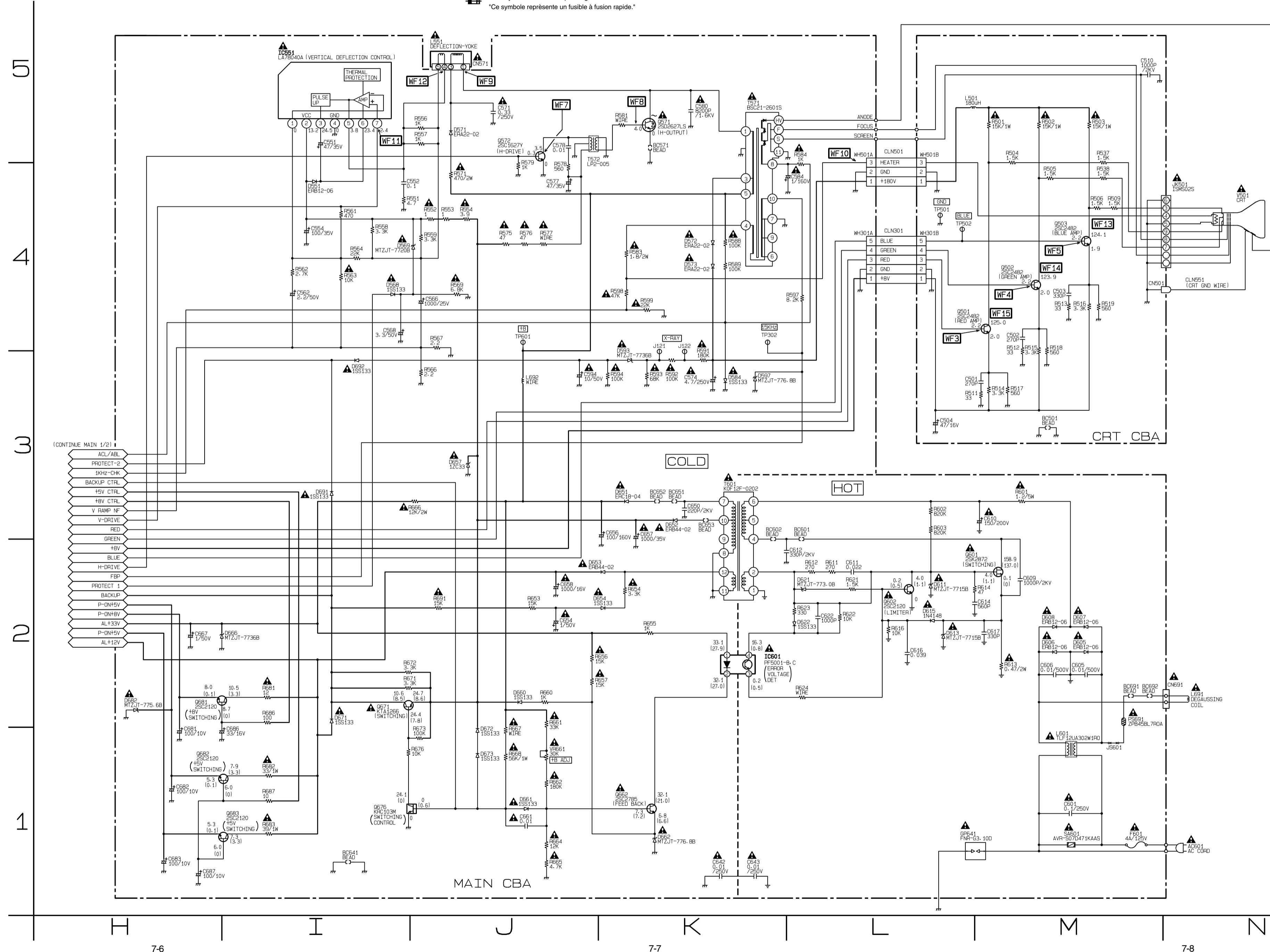

**CRT**

Ref No.	Position
<b>TRANSISTORS</b>	
Q501	L-4
Q502	M-4
Q503	M-4
<b>TEST POINTS</b>	
TP501	L-4
TP502	L-4
<b>CONNECTORS</b>	
CN501	M-4
WH301A	L-4
WH501B	L-5

**MAIN 2/2**

Ref No.	Position
<b>ICS</b>	
IC551	I-5
IC601	K-2
<b>TRANSISTORS</b>	
Q571	K-5
Q572	J-5
Q601	L-2
Q602	L-2
Q662	K-1
Q671	I-2
Q676	I-1
Q681	H-2
Q682	H-1
Q683	I-1
<b>TEST POINTS</b>	
J121	K-4
J122	K-4
TP302	K-4
TP601	J-4
<b>CONNECTORS</b>	
CN571	J-5
CN691	N-2
WH301A	L-4
WH501A	L-5
<b>VARIABLE RESISTORS</b>	
VR661	J-1

H5	I5	J5	K5	L5	M5	N5
H4	I4	J4	K4	L4	M4	N4
H3	I3	J3	K3	L3	M3	N3
H2	I2	J2	K2	L2	M2	N2
H1	I1	J1	K1	L1	M1	N1

VIDEO SIGNAL

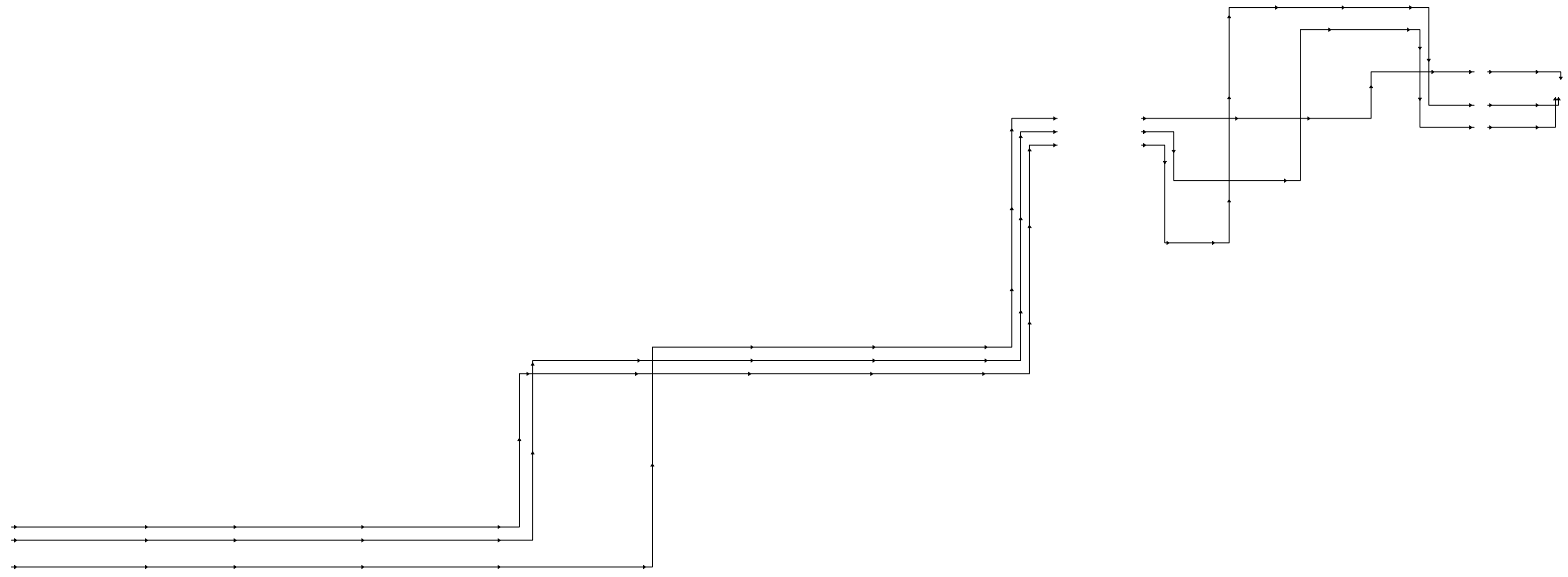



Main CBA Top View

**CAUTION !**  
Fixed voltage power supply circuit is used in this unit.  
If Main Fuse (F601) is blown, check to see that all components in the power supply circuit are not defective before you connect the AC plug to the AC power supply.  
Otherwise it may cause some components in the power supply circuit to fail.

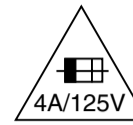

**CAUTION**  
FOR CONTINUED PROTECTION AGAINST FIRE HAZARD,  
REPLACE ONLY WITH THE SAME TYPE FUSE.  
ATTENTION : POUR UNE PROTECTION CONTINUE LES RISQUES  
D'INCENDIE N'UTILISER QUE DES FUSIBLES DE MEME TYPE.  
**RISK OF FIRE-REPLACE FUSE AS MARKED.**  
\*This symbol means fast operating fuse.  
\*Ce symbole représente un fusible à fusion rapide.\*

**BECAUSE A HOT CHASSIS GROUND IS PRESENT IN THE POWER SUPPLY CIRCUIT, AN ISOLATION TRANSFORMER MUST BE USED. ALSO, IN ORDER TO HAVE THE ABILITY TO INCREASE THE INPUT SLOWLY, WHEN TROUBLESHOOTING THIS TYPE POWER SUPPLY CIRCUIT, A VARIABLE ISOLATION TRANSFORMER IS REQUIRED.**

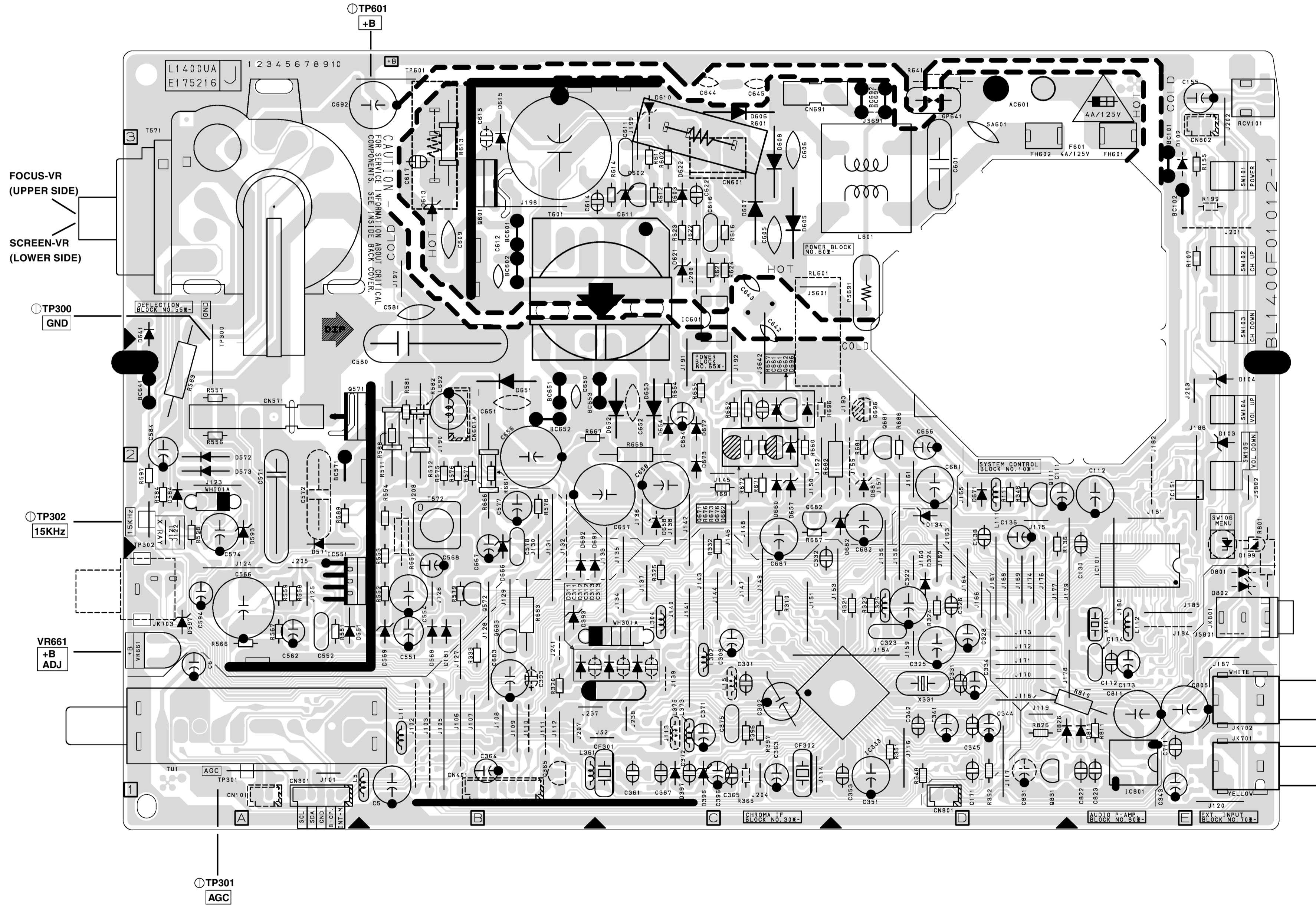

Main CBA Bottom View

**CAUTION !**  
Fixed voltage power supply circuit is used in this unit.  
If Main Fuse (F601) is blown, check to see that all components in the power supply circuit are not defective before you connect the AC plug to the AC power supply. Otherwise it may cause some components in the power supply circuit to fail.

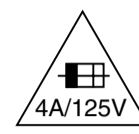

**CAUTION**  
FOR CONTINUED PROTECTION AGAINST FIRE HAZARD,  
REPLACE ONLY WITH THE SAME TYPE FUSE.  
ATTENTION : POUR UNE PROTECTION CONTINUE LES RISQUES  
D'INCELE N'UTILISER QUE DES FUSIBLE DE MEMO TYPE.  
**RISK OF FIRE-REPLACE FUSE AS MARKED.**  
This symbol means fast operating fuse.  
Ce symbole représente un fusible à fusion rapide.\*

BECAUSE A HOT CHASSIS GROUND IS PRESENT IN THE POWER SUPPLY CIRCUIT, AN ISOLATION TRANSFORMER MUST BE USED. ALSO, IN ORDER TO HAVE THE ABILITY TO INCREASE THE INPUT SLOWLY, WHEN TROUBLESHOOTING THIS TYPE POWER SUPPLY CIRCUIT, A VARIABLE ISOLATION TRANSFORMER IS REQUIRED.

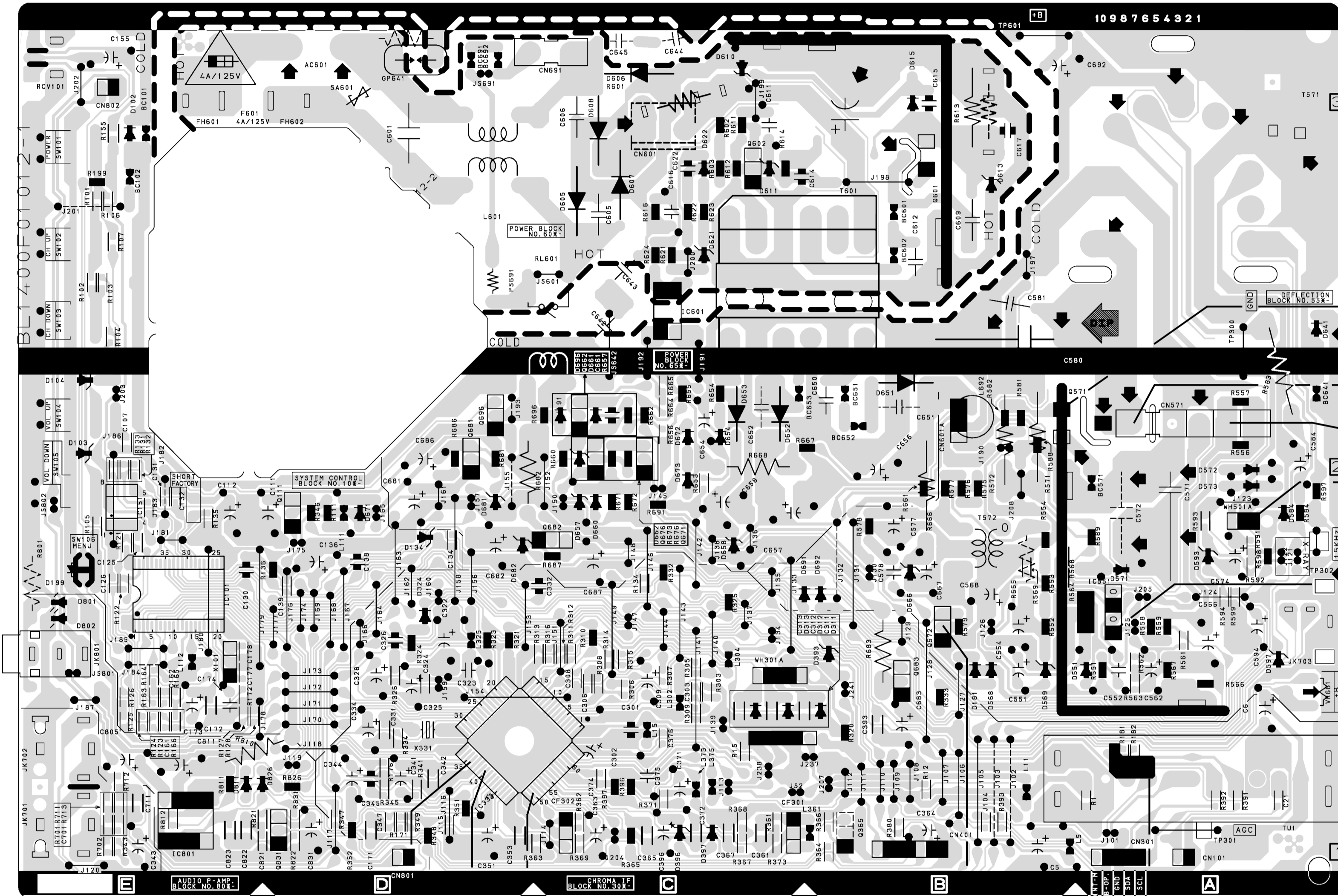

MAIN CBA

Ref No.	Position
ICS	
IC101	E-1
IC151	E-2
IC333	D-1
IC551	A-1
IC601	C-3
IC801	E-1
TRANSISTORS	
Q111	D-2
Q571	A-2
Q572	B-1
Q601	B-3
Q602	C-3
Q662	C-2
Q671	C-2
Q676	C-2
Q681	D-2
Q682	C-2
Q683	B-1
Q831	D-1
TEST POINTS	
J121	A-2
J122	A-2
TP300	A-3
TP301	A-1
TP302	A-2
TP601	B-3
CONNECTORS	
CN301	A-1
CN571	A-2
CN691	C-3
CN801	D-1
WH301A	C-1
WH501A	A-2
VARIABLE RESISTORS	
VR661	A-1

- WF8**  
Q571  
Base
- WF9**  
PIN 1  
OF CN571
- WF12**  
PIN 4  
OF CN571
- WF10**  
PIN 3  
OF WH501A
- WF11**  
PIN 7  
OF IC551

- WF1**  
PIN36  
OF IC301
- WF2**  
PIN 40  
OF IC301
- WF6**  
PIN50  
OF IC301
- WF7**  
Q572  
Collector
- WF16**  
PIN 8  
OF TU1

CRT CBA Top View

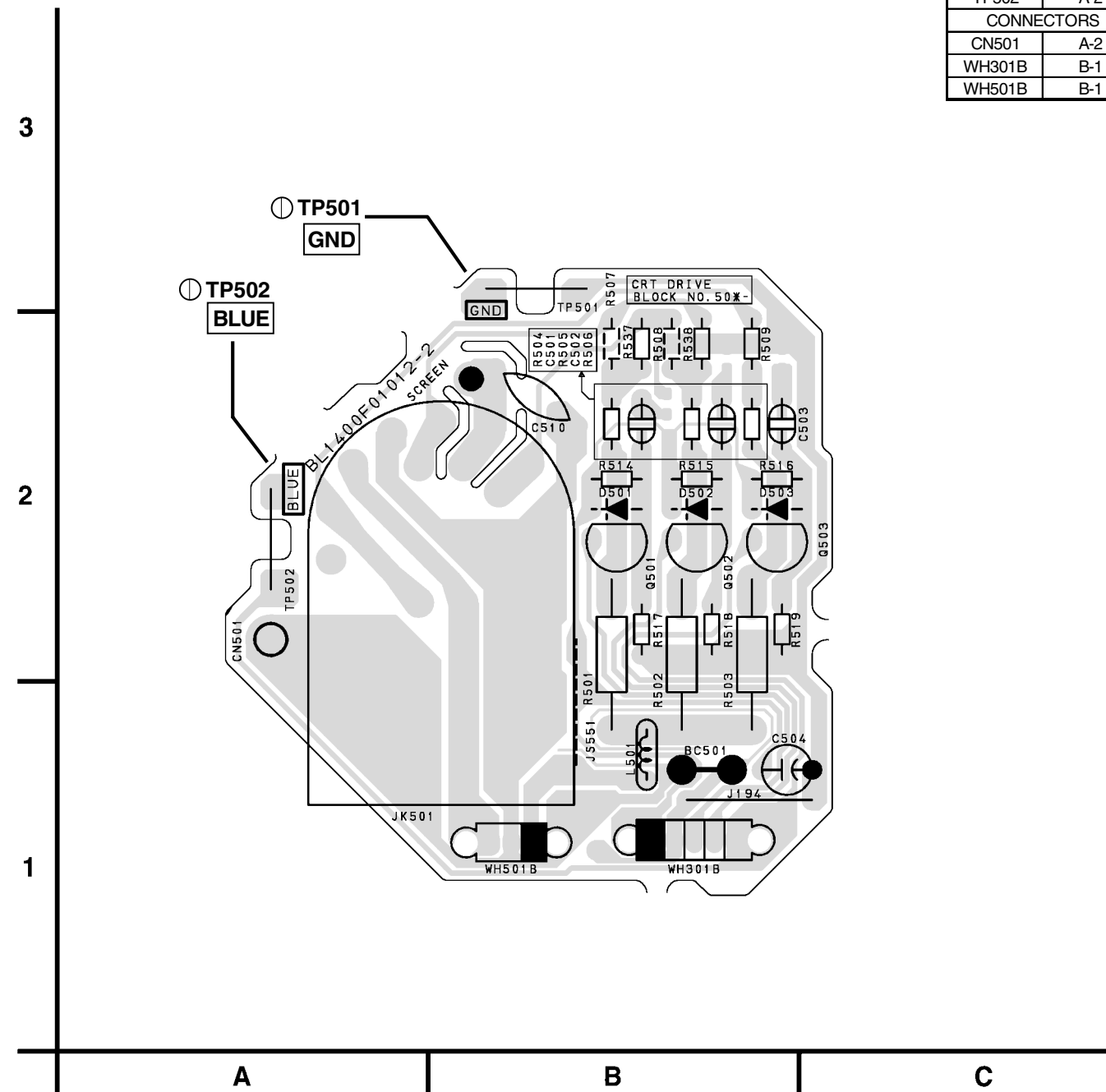

CRT CBA Bottom View

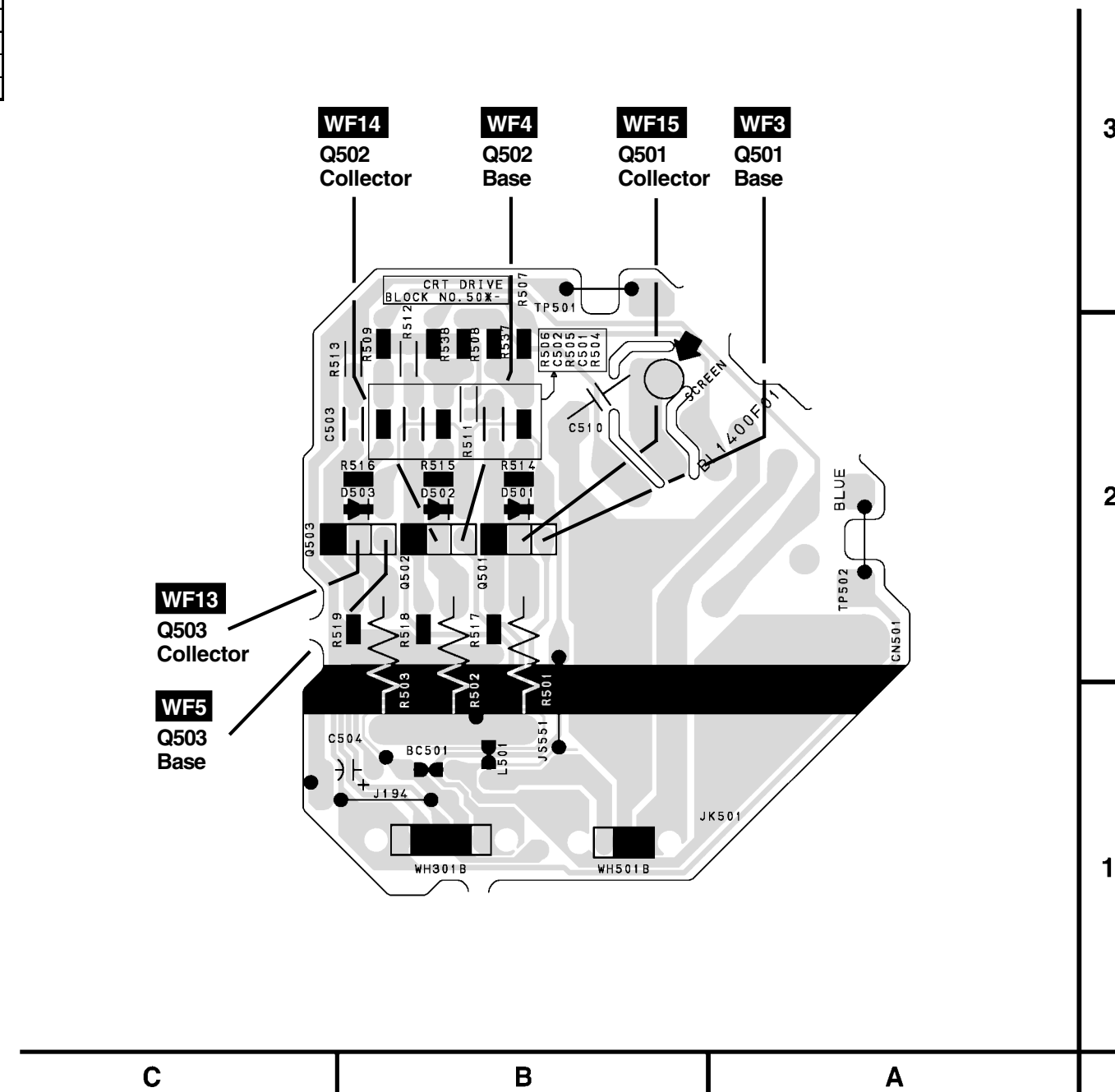

CRT CBA

Ref No.	Position
TRANSISTORS	
Q501	B-2
Q502	B-2
Q503	C-2
TEST POINTS	
TP501	B-3
TP502	A-2
CONNECTORS	
CN501	A-2
WH301B	B-1
WH501B	B-1

# WAVEFORMS

WF1 ~ WF16 = Waveforms to be observed at Waveform check points. (Shown in Schematic Diagram.)

**Input:** NTSC Color Bar Signal (with 1kHz Audio Signal)

**INITIAL POSITION:** Unplug unit from AC outlet for at least 5 minutes. reconnect to AC outlet and then turn power on.

(Brightness---Center Color---Center Tint --- Center Contrast---Approx 70%)

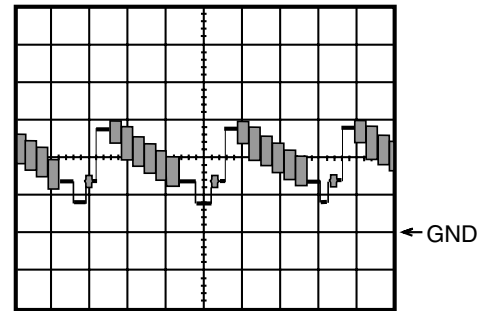

**WF1** 1DIV: 0.5V 20μsec  
C 354 Minus Lead

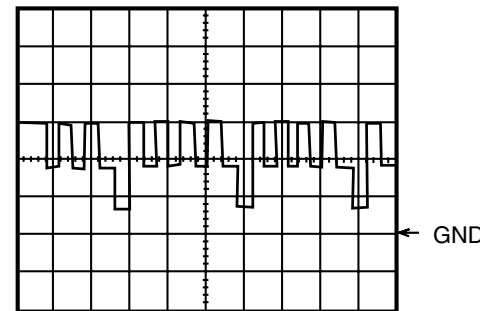

**WF5** 1DIV: 2V 20μsec  
Q 503 Base

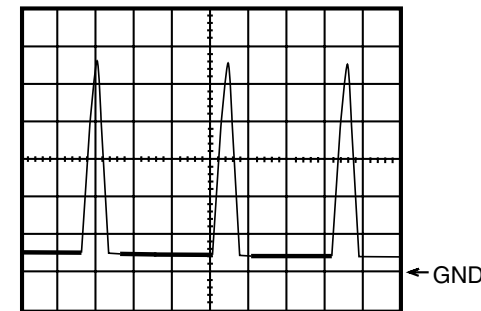

**WF9** 1DIV: 200V 20μsec  
CN 571 Pin 1

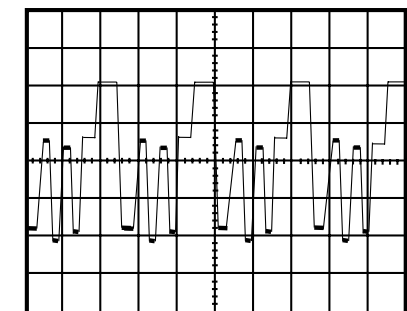

**WF13** 1DIV: 20V 20μsec  
Q503 Collector

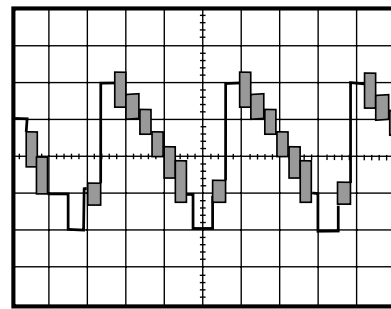

**WF2** 1DIV: 0.5V 20μsec  
IC 301 Pin 40

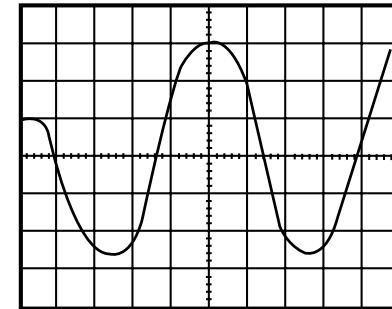

**WF6** 1DIV: 0.2V 20msec  
IC 301 Pin 50

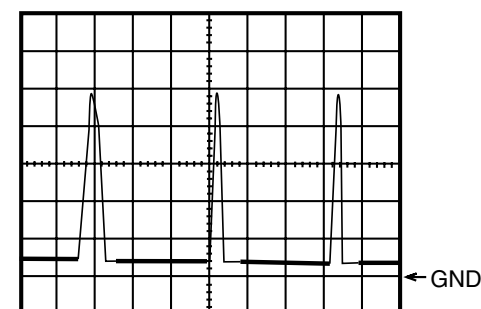

**WF10** 1DIV: 5V 20μsec  
WH501A Pin 2

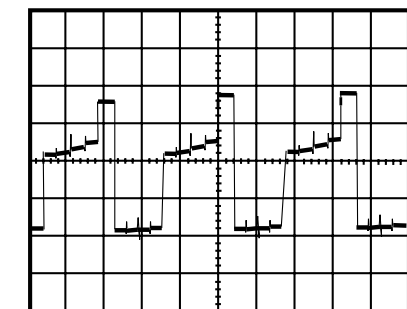

**WF14** 1DIV: 20V 20μsec  
Q 502 Collector

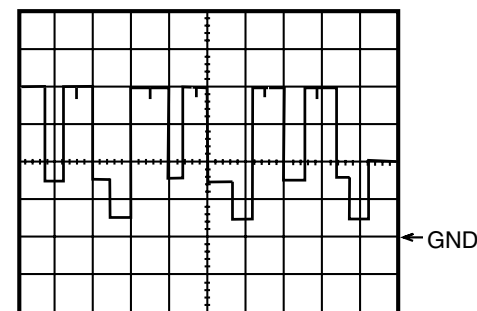

**WF3** 1DIV: 2V 20μsec  
Q501 Base

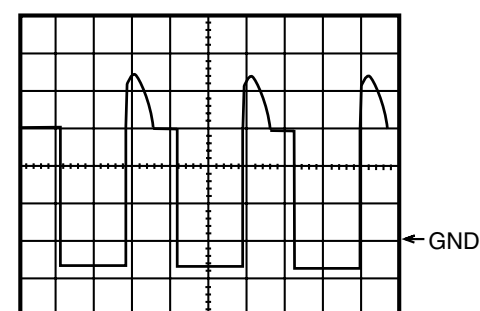

**WF7** 1DIV: 10V 20μsec  
Q 572 Collector

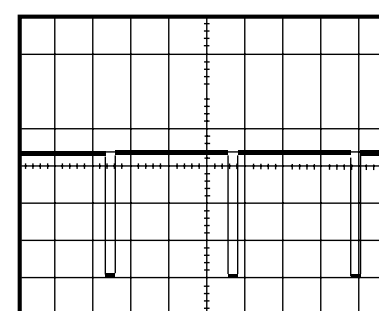

**WF11** 1DIV: 2V 5msec  
IC 551 Pin 7

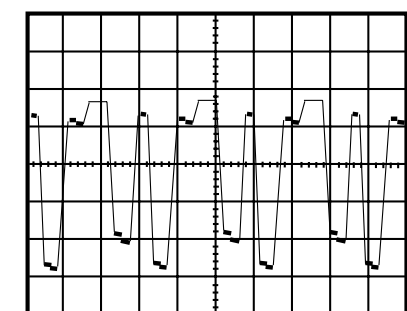

**WF15** 1DIV: 20V 20μsec  
Q 501 Collector

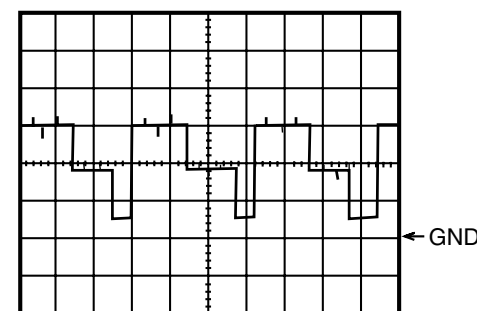

**WF4** 1DIV: 2V 20μsec  
Q 502 Base

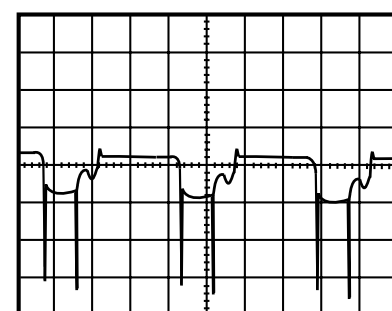

**WF8** 1DIV: 5V 20μsec  
Q 571 Base

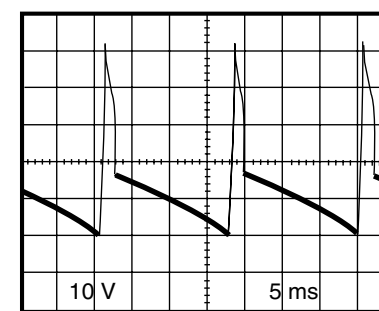

**WF12** 1DIV: 10V 5msec  
CN 571 Pin 4

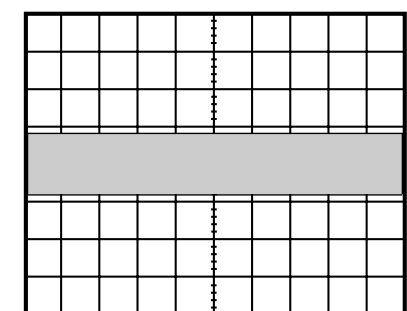

**WF16** 1DIV: 0.2V 20μsec  
TU 1 Pin 8

# WIRING DIAGRAM

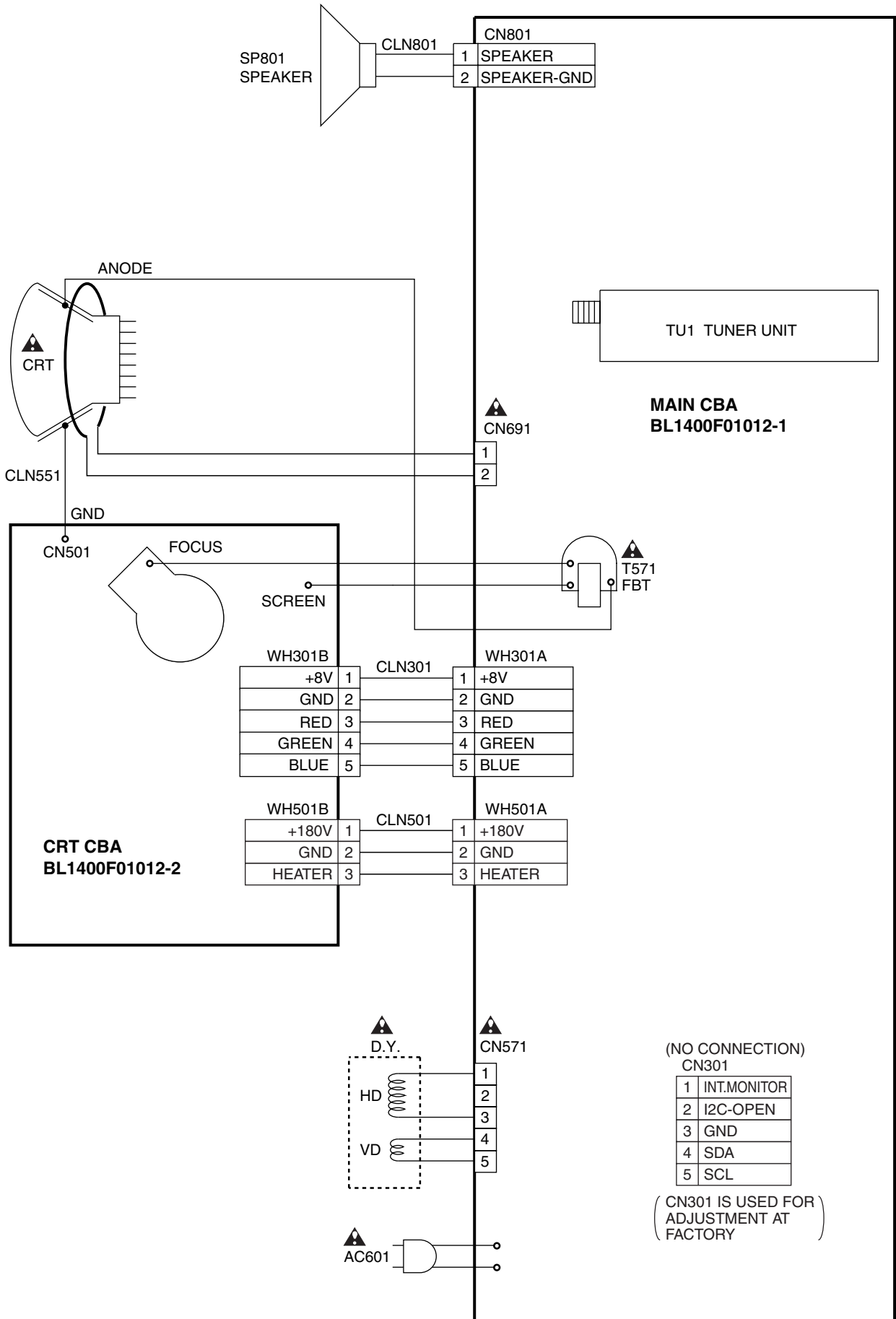

# IC PIN FUNCTIONS

## IC101 (TV Micro Computer)

Pin No.	Signal Name	Function
1	H-SYNC	Input For Horizontal Synchronize Signal
2	V-SYNC	Input For Vertical Synchronize Signal
3	N.U.	Not Used
4	EXT-H	Ext-H (Not Used)
5	N.U.	Not Used
6	A-MUTE-H	Audio Mute
7	N.U.	Not Used
8	N.U.	Not Used
9	N.U.	Not Used
10	REMO-CON	Input For Remote Control
11	SD	Detection SD signal
12	1kHz-CHK	Power Supply Protection
13	P-ON-L	Output for P-ON-L (Not Used)
14	VCC	+5V
15	HLF	Filter for CCD
16	VHOLD	VHOLD
17	CVIN	Input for Video Signal
18	CV Vss	GND
19	XIN	Input for Oscillator
20	XOUT	Output for Oscillator
21	VSS	GND
22	VCC	+5V
23	N.U.	Not Used
24	N.U.	Not Used
25	RESET	RESET
26	PROTECT-1	Power Supply Protection
27	PROTECT-2	Power Supply Protection
28	KEY-IN	Key Input (Main)
29	N.U.	Not Used
30	FACTORY	Factort Key Input
31	SDA	I2C-BUS Controller Interface (Data)
32	I2C-OPEN	White Balance Adjustment Judgement
33	SCL	I2C-BUS Controller Interface (Clock)

Pin No.	Signal Name	Function
34	SPOT-KILL	Spot Countermeasure (Not Used)
35	P-ON-H	Output for P-ON-H
36	N.U.	Not Used
37	N.U.	Not Used
38	N.U.	Not Used
39	OSD-BLK	Picture Shut Down Output
40	OSD-B	Blue Output
41	OSD-G	Green Output
42	OSD-R	Red Output

## IC301 (IF/Video/Chrominance/Deflection)

Pin No.	Signal Name	Function
1	IF IN 2	IF INput 2
2	IF-VCC1	IF-VCC 1
3	IF-VCC2	IF VCC 2
4	H. VCO-FB	H. VCO-FB
5	SCL	SCL
6	FBP- IN	FBP Input
7	H-OUT	H-Output
8	DEF GND 1	DEF GND 1
9	DEF GND 2	DEF GND 2
10	SDA	SDA
11	AFC FILTER 1	AFC Filter 1
12	INV. FBP-OUT	INV. FBP-OUT
13	P-ON-CTRL	Power on Control Output
14	R-OUT	R Output
15	G-OUT	G Output
16	B-OUT	B Output
17	V-OUT	Vertical Out
18	VCC 1	Start up VCC 1
19	VCC 2	Start up VCC 2
20	B-IN	OSD Blue Input
21	V-RAMP NF	V Ramp NF

Pin No.	Signal Name	Function
22	V RAMP	Filter for V Ramp
23	VC-VCC1	VC VCC 1
24	VC-VCC2	VC VCC 2
25	FSC-OUT	Freq. Sub carrier Output
26	SPOT-KILLER	Spot-Killer
27	FAST BLK	Fast Blanking Input
28	G-IN	OSD Green Input
29	V PULSE OUT	V-Pulse Output
30	R-IN	OSD Red Input
31	ACL/ABL	ACL/ABL
32	X-TAL 3.58	Chroma Osc
33	8.7V OUT	8.7V Output
34	EXT-IN	External Input (Not Used)
35	CHROMA APC FILTER	Filter for CHROMA APC
36	TV-IN	TV Input
37	VC GND 1	VC GND 1
38	VC GND 2	VC GND 2
39	VC GND 3	VC GND 3
40	Y-SW OUT	Y-SW Output
41	5.7V OUT	5.7V Output
42	Reset	MCU Reset Output
43	INTERIGENT MONITOR	Interigent Monitor Out
44	Hi Vcc 1	Hi Vcc 1
45	Hi Vcc 2	Hi Vcc 2
46	SW. REG. CONT.	Switching Reg. Control Output
47	SIF LIMITER-IN	SIF Limitter Input
48	IF AGC FILTER 2	Filter for IF AGC
49	QIF OUT	QIF Output
50	AUDIO OUT	Audio Output
51	AUDIO BYPASS	Filter for Audio Bypass

Pin No.	Signal Name	Function
52	EXT AUDIO IN	External Audio In (Not Used)
53	FM DETECT OUT	RF Output
54	VIF VCO-FB	VIF VCO-FB
55	REG. Vcc IN	REG. Vcc Input
56	VIDEO APC FILTER	Filter for Video APC
57	VIDEO OUT	Video Out
58	IF GND 1	GND 1
59	IF GND 2	GND 2
60	AFT OUT	AFT Out
61	QIF IN	QIF Input (Not Used)
62	RF AGC OUT	RF AGC Out
63	IF AGC FILTER 1	Filter for IF AGC
64	IF IN 1	IF Input 1

# EXPLODED VIEWS

## Cabinet

See Electrical Parts List for parts with this mark.  
Some Ref. Number are not in sequence.

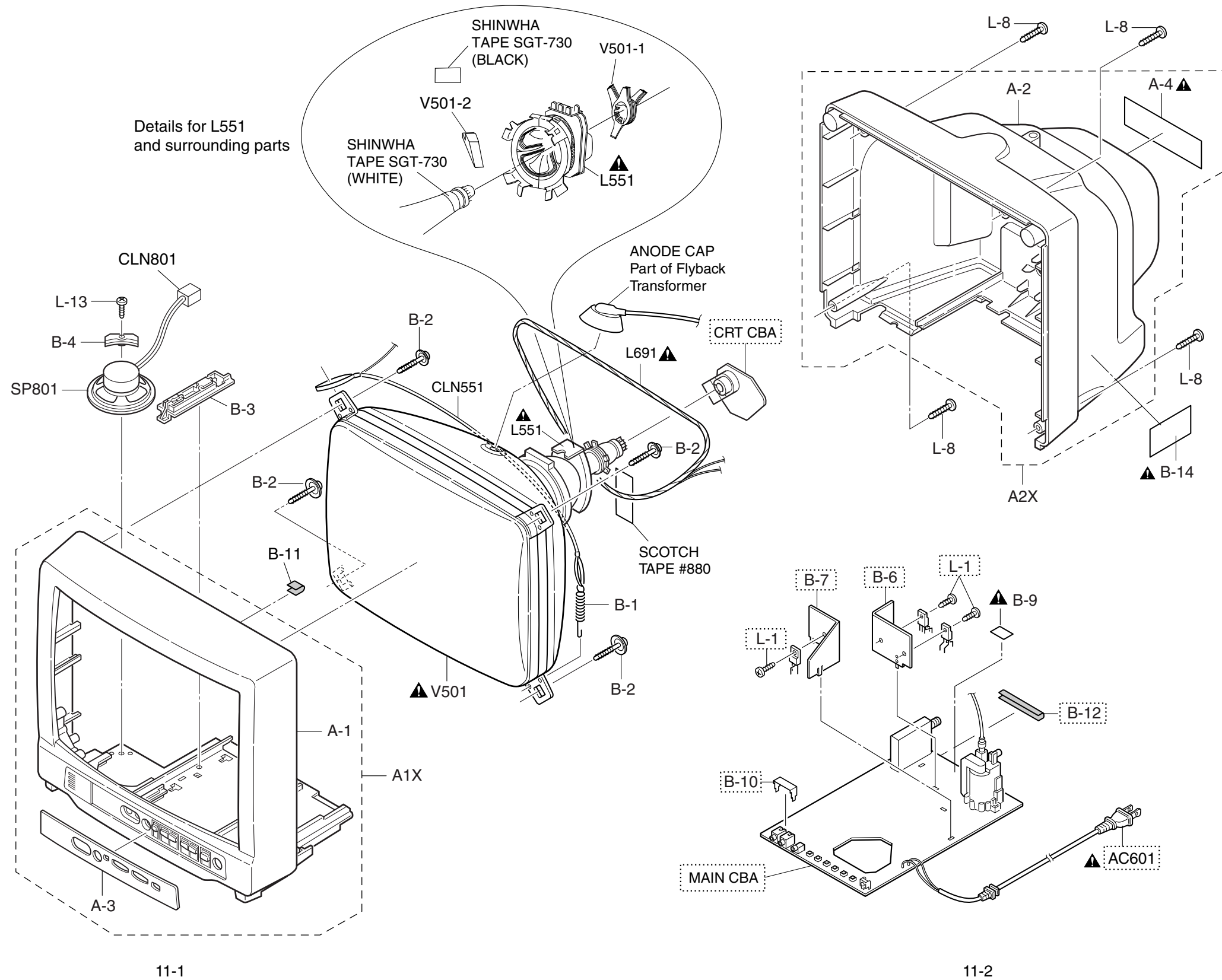



# Packing

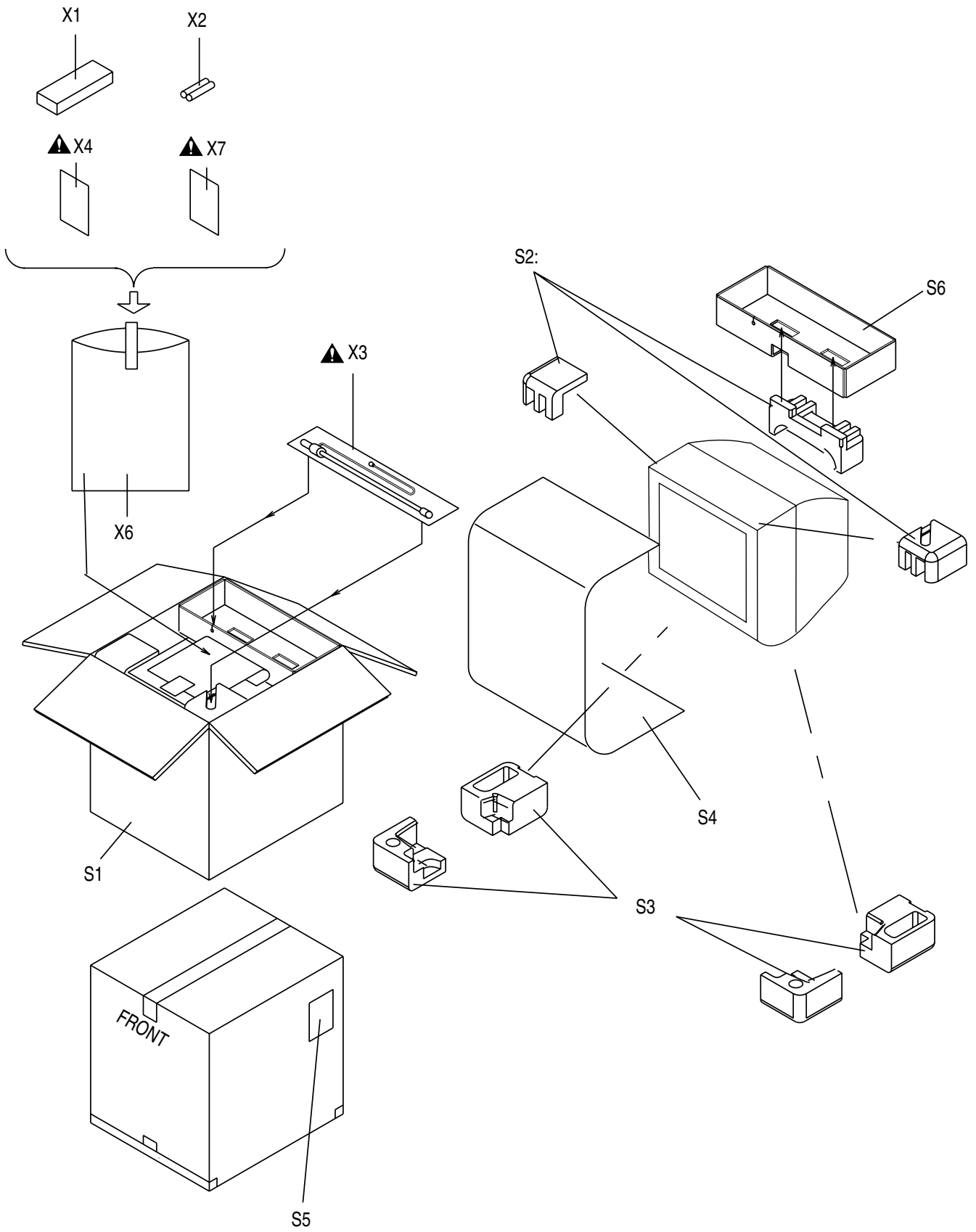

# MECHANICAL PARTS LIST

**PRODUCT SAFETY NOTE:** Products marked with a **▲** have special characteristics important to safety. Before replacing any of these components, read carefully the product safety notice in this service manual. Don't degrade the safety of the product through improper servicing.

Ref. No.	Description	Part No.
A-1	FRONT CABINET L1300UA	0EM000485
A-2	REAR CABINET L7900UA	0EM000481
A-3	CONTROL PLATE L1302UC	0EM301443
A-4▲	RATING LABEL L1304CE	0EM406234
A1X	FRONT CABINET ASSEMBLY L1302UC	0EM201385
A2X	REAR CABINET ASSEMBLY L1304CE	0EM201398
AC601▲	AC CORD LA-2366 (See Electrical Parts List) or	
▲	AC CORD WAC0172AS006 (See Electrical Parts List) or	
▲	AC CORD WAC0172LTE01 (See Electrical Parts List)	
B-1	TENSION SPRING B0080B0:EM40808	26WH006
B-2	M5 CRT SCREW(B) B4000UA	0VM403923
B-3	PCB HOLDER L1300UA	0EM301412
B-4	SPEAKER HOLDER L1300UA	0EM406030
B-6	HEAT SINK(PFC)ASSEMBLY L7900UZ (See Electrical Parts List)	
B-7	HEAT SINK(PFA) L1400UZ (See Electrical Parts List)	
B-9▲	CHASSIS NO. LABEL L1304CZ	0EM406229
B-10	JACK HOLDER L9304UZ (See Electrical Parts List)	
B-11	CLOTH(B) L5201U0:15X10X1.0T	0EM400076
B-12	CLOTH(65) L7735TR:65X10X0.5T (See Electrical Parts List)	
B-14▲	CRITICAL PARTS WARNING LABEL B8007C3:EM41210	24LH199
L-1	B-TITE SCREW 3X8 BIND + CHROME (See Electrical Parts List) or	
	B-TITE SCREW 3X8 BIND + CHROME (See Electrical Parts List)	
L-8	SCREW, P-TIGHT 4X18 BIND HEAD +	GBMP4180
L-13	SCREW, P-TIGHT 3X12 BIND HEAD+	GBMP3120
<b>PACKING</b>		
S-1	CARTON L1304CE	0EM301466
S-2	STYRFOAM TOP L1300UA	0EM101089
S-3	STYRFOAM BOTTOM L1300UA	0EM000503
S-4	SET SHEET B5506UG:800X1500	0EM402369
S-5	SERIAL NO. LABEL L1304CE	0EM406235
S-6	HOLD PAD L1300UA	0EM301535
<b>ACCESSORIES</b>		
X-1	REMOCON UNIT 130/ERC001/N0108UD or	N0108UD
	REMOCON UNIT 130/ERC001/N0132UD	N0132UD
X-2	DRY BATTERY R6P UM3 or	XB0M451GH001
	DRY BATTERY R6P/2S or	XB0M451T0001
	DRY BATTERY(SUNRISE) R6SSE/2S or	XB0M451MS002
	DRY BATTERY R6P(AR)2PX or	XB0M451HU002
	DRY BATTERY R6P(AR)2P X ICI	XB0M451HU003
X-3▲	ROD ANTENNA L7720UA:NTSC W/COO or	0EMN00673
▲	ROD ANTENNA T5000UA	0EMN01599
X-4▲	OWNER'S MANUAL(E)/(S) L1304CE:ENGLISH/ SPANISH	0EMN01775
X-6	POLYETHYLENE BAG F8626B5	Z325350

Ref. No.	Description	Part No.
X-7▲	QUICK SETUP GUIDE L1004CE	0EMN01726
<b>DE PARTS</b>		
CLN551	CRT GND WIRE CRT GND	WX1L7720-001
CLN801	WIRE ASSEMBLY	WX1L9200-001
L691▲	DEGAUSSING COIL F-017 or	LLBH00ZTM017
▲	DEGAUSSING COIL AVDG013 or	LLBH00ZWR017
▲	DEGAUSSING COIL or	LLBH00ZTZ017
▲	DEGAUSSING COIL LLBH00ZTM022	LLBH00ZTM022
SP801	SPEAKER S08F02B or	DSD0808XQ010
	SPEAKER J-F097-C5	DSD0808DCP01
<b>Note:</b> 1. V501 (CRT) HAS COUPLE OF SUBSTITUTIONAL PARTS AND EACH PARTS ALSO HAS MATCHING COMBINATION WITH L551. PLEASE SEE TABLE 1 FOR DETAILS OF MATCHING COMBINATION. 2. L551 (DEFLECTION YOKE) HAS MATCHING COMBINATION WITH V501. PLEASE SEE TABLE 1 FOR DETAILS OF MATCHING COMBINATION.		
<b>CRT TYPE 1</b>		
L551▲	DEFLECTION YOKE KDY3GDA82X or	LLBY00ZMS011
▲	DEFLECTION YOKE LLBY00ZSY005	LLBY00ZSY005
V501▲	CRT A34AGT13X	TCRT190CP036
V501-1	C.P.MAGNET JH225-FN-00	XM04000BV003
V501-2	WEDGE FT-00110W or	XV10000T4001
	WEDGE DB25SR	XV10000D9001
<b>CRT TYPE 2</b>		
L551▲	DEFLECTION YOKE LLBY00ZSY002 or	LLBY00ZSY002
▲	DEFLECTION YOKE KDY3GC587X	LLBY00ZMS003
V501▲	CRT A34KPU02XX	TCRT190GS016
V501-1	C.P.MAGNET JH225-FN-00	XM04000BV003
V501-2	WEDGE FT-00110W or	XV10000T4001
	WEDGE DB25SR	XV10000D9001
<b>CRT TYPE 3</b>		
L551▲	DEFLECTION YOKE KDY3GCB05X	LLBY00ZMS014
V501▲	CRT A34LEX10X	TCRT190SAM01
V501-1	C.P.MAGNET JH225-FN-00	XM04000BV003
V501-2	WEDGE FT-00110W or	XV10000T4001
	WEDGE DB25SR	XV10000D9001
<b>CRT TYPE 4</b>		
L551▲	DEFLECTION YOKE KDY3GD591X or	LLBY00ZMS005
▲	DEFLECTION YOKE CDY-M1422F	LLBY00ZQS001
V501▲	CRT A34JLL90X(W)	TCRT190QS015
V501-1	C.P.MAGNET JH225-FN-00	XM04000BV003
V501-2	WEDGE FT-00110W or	XV10000T4001
	WEDGE DB25SR	XV10000D9001
<b>CRT TYPE 5</b>		
L551▲	DEFLECTION YOKE LLBY00ZSY002 or	LLBY00ZSY002
▲	DEFLECTION YOKE CDY-M1456S	LLBY00ZQS008
V501▲	CRT A34KQW42X	TCRT190SM013
V501-1	C.P.MAGNET JH225-FN-00	XM04000BV003
V501-2	WEDGE FT-00110W or	XV10000T4001
	WEDGE DB25SR	XV10000D9001
<b>CRT TYPE 6</b>		
L551▲	DEFLECTION YOKE LLBY00ZSY003 or	LLBY00ZSY003
▲	DEFLECTION YOKE KDY3GD592X or	LLBY00ZMS004
▲	DEFLECTION YOKE CDY-M1455F	LLBY00ZQS007
V501▲	CRT A34LRQ90X(VW)	TCRT190P7003
V501-1	C.P.MAGNET JH225-FN-00	XM04000BV003
V501-2	WEDGE FT-00110W or	XV10000T4001
	WEDGE DB25SR	XV10000D9001

## Table 1 (V501 and L551 Combination)

**Note 1:** Purity and Convergence Adjustments must be performed following CRT replacement. Refer to Electrical Adjustment Instructions.

**Note2:** Please confirm CRT Type No. on the CRT Warning Label which is located on the CRT. Then See the Table 1 for V501 and L551 combination chart. Please refer this CRT, Deflection Yoke combination chart for parts order.

V501: CRT Type No.	V501: CRT Part No.	L551: Deflection Yoke Part No.
CRT A34AGT13X	TCRT190CP036	LLBY00ZMS011
		LLBY00ZSY005
CRT A34KPU02XX	TCRT190GS016	LLBY00ZSY002
		LLBY00ZMS003
CRT A34LEX10X	TCRT190SAM01	LLBY00ZMS014
CRT A34JLL90X(W)	TCRT190QS015	LLBY00ZMS005
		LLBY00ZQS001
CRT A34KQW42X	TCRT190SM013	LLBY00ZSY002
		LLBY00ZQS008
CRT A34LRQ90X(VW)	TCRT190P7003	LLBY00ZSY003
		LLBY00ZMS004
		LLBY00ZQS007

## CRT Warning Label Location

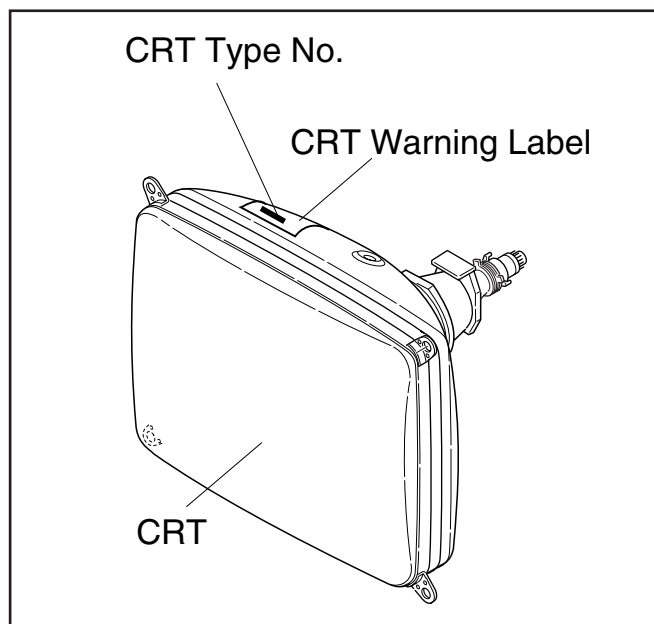

# ELECTRICAL PARTS LIST

**PRODUCT SAFETY NOTE:** Products marked with a **▲** have special characteristics important to safety. Before replacing any of these components, read carefully the product safety notice in this service manual. Don't degrade the safety of the product through improper servicing.

## NOTES:

- Parts that not assigned part numbers (-----) are not available.
- Tolerance of Capacitors and Resistors are noted with the following symbols.

C.....±0.25%    D.....±0.5%    F.....±1%  
 G.....±2%    J.....±5%    K.....±10%  
 M.....±20%    N.....±30%    Z.....+80/-20%

## MMA-325 CBA

Ref. No.	Description	Part No.
	MMA-325 CBA Consists of the following	0ESA04097
	Main CBA CRT CBA	----- -----

## Main CBA

Ref. No.	Description	Part No.
	Main CBA Consists of the following	-----
<b>CAPACITORS</b>		
C5	ELECTROLYTIC CAP. 100µF/10V M or ELECTROLYTIC CAP. 100µF/10V M	CE1AMASTL101 CE1AMASDL101
C6	ELECTROLYTIC CAP. 4.7µF/50V M or ELECTROLYTIC CAP. 4.7µF/50V M	CE1JMASTL4R7 CE1JMASDL4R7
C107	CHIP CERAMIC CAP. B K 0.01µF/50V	CHD1JKB0B103
C111	ELECTROLYTIC CAP. 47µF/16V M or ELECTROLYTIC CAP. 47µF/16V M	CE1CMASL470 CE1CMASDL470
C112	ELECTROLYTIC CAP. 100µF/10V M or ELECTROLYTIC CAP. 100µF/10V M	CE1AMASTL101 CE1AMASDL101
C113	CERAMIC CAP.(AX) F Z 0.01µF/25V	CDA1EZT0F103
C125	CHIP CERAMIC CAP. CH J 47pF/50V	CHD1JJBCH470
C130	CERAMIC CAP.(AX) B K 220pF/50V	CCA1JKT0B221
C131	CHIP CERAMIC CAP. CH J 100pF/50V	CHD1JJBCH101
C132	CHIP CERAMIC CAP. CH J 220pF/50V	CHD1JJBCH221
C136	ELECTROLYTIC CAP. 4.7µF/50V M or ELECTROLYTIC CAP. 4.7µF/50V M	CE1JMASTL4R7 CE1JMASDL4R7
C139	CHIP CERAMIC CAP. F Z 0.1µF/25V	CHD1EZB0F104
C155	ELECTROLYTIC CAP. 47µF/16V M or ELECTROLYTIC CAP. 47µF/16V M	CE1CMASL470 CE1CMASDL470
C161	CHIP CERAMIC CAP. B K 0.01µF/50V	CHD1JKB0B103
C162	CHIP CERAMIC CAP. B K 0.047µF/50V or CHIP CERAMIC CAP. B K 0.047µF/25V	CHD1JKB0B473 CHD1EKB0B473
C171	CHIP CERAMIC CAP. CH J 220pF/50V	CHD1JJBCH221
C172	CHIP CERAMIC CAP. CH J 220pF/50V	CHD1JJBCH221
C173	ELECTROLYTIC CAP. 1µF/50V M or ELECTROLYTIC CAP. 1µF/50V M or ELECTROLYTIC CAP. 1µF/50V M or	CE1JMASTL1R0 CE1JMASTL010 CE1JMASDL1R0

Ref. No.	Description	Part No.
	ELECTROLYTIC CAP. 1µF/50V M	CE1JMASDL010
C174	FILM CAP.(P) 0.001µF/50V J or FILM CAP.(P) 0.001µF/50V J or FILM CAP.(P) 0.001µF/50V J TV or *MYLAR CAP. 0.001µF/50V K	CMA1JJS00102 CA1J102MS029 CMB1JJS00102 2250102S
C302	ELECTROLYTIC CAP. 220µF/10V M or ELECTROLYTIC CAP. 220µF/10V M	CE1AMZPTL221 CE1AMZPDL221
C303	CHIP CERAMIC CAP. B K 0.01µF/50V	CHD1JKB0B103
C306	CHIP CERAMIC CAP. CH J 330pF/50V	CHD1JJBCH331
C308	CHIP CERAMIC CAP. B K 0.01µF/50V	CHD1JKB0B103
C309	ELECTROLYTIC CAP. 1µF/50V M or ELECTROLYTIC CAP. 1µF/50V M or ELECTROLYTIC CAP. 1µF/50V M or ELECTROLYTIC CAP. 1µF/50V M	CE1JMASTL1R0 CE1JMASTL010 CE1JMASDL1R0 CE1JMASDL010
C322	ELECTROLYTIC CAP. 100µF/10V M or ELECTROLYTIC CAP. 100µF/10V M	CE1AMASTL101 CE1AMASDL101
C323	FILM CAP.(P) 0.1µF/50V J or FILM CAP.(P) 0.1µF/50V J or FILM CAP.(P) 0.1µF/50V J TV or MYLAR CAP. 0.1µF/50V K	CMA1JJS00104 CA1J104MS029 CMB1JJS00104 2250104S
C325	ELECTROLYTIC CAP. 100µF/10V M or ELECTROLYTIC CAP. 100µF/10V M	CE1AMASTL101 CE1AMASDL101
C326	CERAMIC CAP.(AX) F Z 0.01µF/25V	CDA1EZT0F103
C328	ELECTROLYTIC CAP. 10µF/50V M or ELECTROLYTIC CAP. 10µF/50V M	CE1JMASTL100 CE1JMASDL100
C331	CHIP CERAMIC CAP. CH J 47pF/50V	CHD1JJBCH470
C332	CERAMIC CAP.(AX) UP050F104Z-A-B or CERAMIC CAP.(AX) F Z 0.1µF/50V	CA1J104TU014 CCA1JZT0F104
C334	ELECTROLYTIC CAP. 1µF/50V M or ELECTROLYTIC CAP. 1µF/50V M or ELECTROLYTIC CAP. 1µF/50V M or ELECTROLYTIC CAP. 1µF/50V M	CE1JMASTL1R0 CE1JMASTL010 CE1JMASDL1R0 CE1JMASDL010
C341	ELECTROLYTIC CAP. 1µF/50V M or ELECTROLYTIC CAP. 1µF/50V M or ELECTROLYTIC CAP. 1µF/50V M or ELECTROLYTIC CAP. 1µF/50V M	CE1JMASTL1R0 CE1JMASTL010 CE1JMASDL1R0 CE1JMASDL010
C342	CERAMIC CAP.(AX) B K 0.015µF/50V	CA1J153TU011
C343	ELECTROLYTIC CAP. 0.1µF/50V M or ELECTROLYTIC CAP. 0.1µF/50V M or ELECTROLYTIC CAP. 0.1µF/50V M or ELECTROLYTIC CAP. 0.1µF/50V M	CE1JMASTLR10 CE1JMASTLOR1 CE1JMASDLR10 CE1JMASDLOR1
C344	ELECTROLYTIC CAP. 0.47µF/50V M or ELECTROLYTIC CAP. 0.47µF/50V M	CE1JMASTLR47 CE1JMASDLR47
C345	CERAMIC CAP.(AX) UP050F104Z-A-B or CERAMIC CAP.(AX) F Z 0.1µF/50V	CA1J104TU014 CCA1JZT0F104
C351	ELECTROLYTIC CAP. 470µF/10V M or ELECTROLYTIC CAP. 470µF/10V M	CE1AMASTL471 CE1AMASDL471
C353	CHIP CERAMIC CAP. B K 0.047µF/50V or CHIP CERAMIC CAP. B K 0.047µF/25V	CHD1JKB0B473 CHD1EKB0B473
C361	CHIP CERAMIC CAP. CH J 680pF/50V	CHD1JJBCH681
C363	ELECTROLYTIC CAP. 2.2µF/50V M LL	CE1JMASLL2R2
C364	ELECTROLYTIC CAP. 2.2µF/50V M or ELECTROLYTIC CAP. 2.2µF/50V M	CE1JMASTL2R2 CE1JMASDL2R2
C365	CERAMIC CAP.(AX) X K 3900pF/16V	CDA1CKT0X392
C367	CHIP CERAMIC CAP. B K 0.01µF/50V	CHD1JKB0B103
C371	ELECTROLYTIC CAP. 0.47µF/50V M or ELECTROLYTIC CAP. 0.47µF/50V M	CE1JMASTLR47 CE1JMASDLR47

\*Mylar is a registered trademark of E.I. Du Pont de Nemours and Company.

Ref. No.	Description	Part No.
C372	CHIP CERAMIC CAP. CH J 33pF/50V	CHD1JJBCH330
C374	CHIP CERAMIC CAP. B K 0.01μF/50V	CHD1JKB0B103
C375	FILM CAP.(P) 0.047μF/50V J or	CMA1JJS00473
	FILM CAP.(P) 0.047μF/50V J or	CA1J473MS029
	FILM CAP.(P) 0.047μF/50V J TV or	CMB1JJS00473
	MYLAR CAP. 0.047μF/50V K	2250473S
C376	CHIP RES. 1/10W J 0 Ω	RRXAJB5Z0000
C393	CHIP CERAMIC CAP. F Z 0.1μF/25V	CHD1EZB0F104
C396	ELECTROLYTIC CAP. 10μF/50V M or	CE1JMASTL100
	ELECTROLYTIC CAP. 10μF/50V M	CE1JMASDL100
C551	ELECTROLYTIC CAP. 47μF/35V M or	CE1GMASTL470
	ELECTROLYTIC CAP. 47μF/35V M	CE1GMASDL470
C552	FILM CAP.(P) 0.1μF/50V J or	CMA1JJS00104
	FILM CAP.(P) 0.1μF/50V J or	CA1J104MS029
	FILM CAP.(P) 0.1μF/50V J TV or	CMB1JJS00104
	MYLAR CAP. 0.1μF/50V K	2250104S
C554	ELECTROLYTIC CAP. 100μF/35V M or	CE1GMASTL101
	ELECTROLYTIC CAP. 100μF/35V M	CE1GMASDL101
C562	ELECTROLYTIC CAP. 2.2μF/50V M LL	CE1JMASLL2R2
C566	ELECTROLYTIC CAP. 1000μF/25V M or	CE1EMZNTL102
	ELECTROLYTIC CAP. 1000μF/25V M or	CE1EMZPDL102
	ELECTROLYTIC CAP. 1000μF/25V M	CE1EMZADL102
C568	ELECTROLYTIC CAP. 3.3μF/50V M or	CE1JMASTL3R3
	ELECTROLYTIC CAP. 3.3μF/50V M	CE1JMASDL3R3
C571▲	PP CAP. 0.33μF/200V J or	CT2E334MS040
▲	P.P. CAP. 0.33μF/200V J or	CA2D334KF002
▲	P.P. CAP 0.33μF/200V J or	CA2D334VC012
▲	PP CAP. 0.33μF/250V J	CT2E334MS041
C574▲	ELECTROLYTIC CAP. 4.7μF/250V M or	CE2EMASTL4R7
▲	ELECTROLYTIC CAP. 4.7μF/250V M	CE2EMASDL4R7
C577	ELECTROLYTIC CAP. 47μF/35V M or	CE1GMASTL470
	ELECTROLYTIC CAP. 47μF/35V M	CE1GMASDL470
C578	FILM CAP.(P) 0.01μF/50V J or	CMA1JJS00103
	FILM CAP.(P) 0.01μF/50V J or	CA1J103MS029
	FILM CAP.(P) 0.01μF/50V J TV or	CMB1JJS00103
	MYLAR CAP. 0.01μF/50V K	2250103S
C580▲	METALLIZED FILM CAP. 0.0082μF/1.6kV J or	CT3C822F7002
▲	METALLIZED FILM CAP. 0.0082μF/1.6kV J or	1220499
▲	P.P. CAP 0.0082μF/1.6K J	CA3C822VC011
C584▲	ELECTROLYTIC CAP. 1μF/160V M or	CE2CMASSTL1R0
▲	ELECTROLYTIC CAP. 1μF/160V M	CE2CMASDL1R0
C594▲	ELECTROLYTIC CAP. 10μF/50V M or	CE1JMASTL100
▲	ELECTROLYTIC CAP. 10μF/50V M	CE1JMASDL100
C601▲	METALLIZED FILM CAP. 0.1μF/250V or	CT2E104MS037
▲	FILM CAP.(MP) 0.1μF/250V M or	CT2E104DC009
▲	FILM CAP.(MP) 0.1μF/250V K	CT2E104DC011
C605	CERAMIC CAP. F Z 0.01μF/500V or	CCD2JZD0F103
	CERAMIC CAP. 0.01μF/AC250V	CCD2EZA0F103
C606	CERAMIC CAP. F Z 0.01μF/500V or	CCD2JZD0F103
	CERAMIC CAP. 0.01μF/AC250V	CCD2EZA0F103
C609	CERAMIC CAP. B K 1000pF/2kV or	CCD3DKD0B102
	CERAMIC CAP. B K 1000pF/2kV or	CCD3DKP0B102
	CERAMIC CAP. B K 1000pF/2kV	CA3D102MR030
C610▲	ALUMINIUM ELECTROLYTIC CAP 150μF/200V or	CA2D151NC088
▲	ELECTROLYTIC CAPACITOR 150μF/200V	CA2D151S6012
C611	FILM CAP.(P) 0.022μF/50V J or	CMA1JJS00223
	FILM CAP.(P) 0.022μF/50V J or	CA1J223MS029
	FILM CAP.(P) 0.022μF/50V J TV or	CMB1JJS00223
	MYLAR CAP. 0.022μF/50V K	2250223S
C612	CERAMIC CAP. LB 330pF/2kV or	CA3D331KG004

Ref. No.	Description	Part No.
	CERAMIC CAP. BN 330pF/2kV or	CCD3DKA0B331
	CERAMIC CAP. 330pF/2kV	CA3D331PAN04
C614	CERAMIC CAP.(AX) B K 560pF/50V	CCA1JKT0B561
C616	FILM CAP.(P) 0.039μF/50V J or	CMA1JJS00393
	FILM CAP.(P) 0.039μF/50V J or	CA1J393MS029
	FILM CAP.(P) 0.039μF/50V J TV or	CMB1JJS00393
	MYLAR CAP. 0.039μF/50V K	2250393S
C617	CERAMIC CAP.(AX) B K 330pF/50V	CCA1JKT0B331
C622	CERAMIC CAP.(AX) B K 1000pF/50V	CCA1JKT0B102
C642▲	SAFETY CAP. 10000pF/250V or	CCG2EMA0F103
▲	SAFETY CAP. F M 0.01μF/250V or	CCG2EMP0F103
▲	CERAMIC CAP. 0.01UF F CS	CCG2HMN0F103
C643▲	SAFETY CAP. 10000pF/250V or	CCG2EMA0F103
▲	SAFETY CAP. F M 0.01μF/250V or	CCG2EMP0F103
▲	CERAMIC CAP. 0.01UF F CS	CCG2HMN0F103
C650	CERAMIC CAP. LB 220pF/2kV or	CA3D221KG004
	CERAMIC CAP. BN J 220pF/2kV or	CCD3DKA0B221
	CERAMIC CAP. 220pF/2kV	CA3D221PAN04
C654▲	ELECTROLYTIC CAP. 1μF/50V M or	CE1JMASTL1R0
▲	ELECTROLYTIC CAP. 1μF/50V M or	CE1JMASTL010
▲	ELECTROLYTIC CAP. 1μF/50V M or	CE1JMASDL1R0
▲	ELECTROLYTIC CAP. 1μF/50V M	CE1JMASDL010
C656	ELECTROLYTIC CAP. 100μF/160V M or	CE2CMZPTL101
	ELECTROLYTIC CAP. 100μF/160V M	CE2CMZNDL101
C657▲	ELECTROLYTIC CAP. 1000μF/35V M or	CE1GMZNTL102
▲	ELECTROLYTIC CAP. 1000μF/35V M	CE1GMZADL102
C658▲	ELECTROLYTIC CAP. 1000μF/16V M(VR/HC) or	CE1CMZNTL102
▲	ELECTROLYTIC CAP. 1000μF/16V M or	CE1CMZPDL102
▲	ELECTROLYTIC CAP. 1000μF/16V M	CE1CMZADL102
C661▲	CERAMIC CAP.(AX) F Z 0.01μF/25V	CDA1EZT0F103
C667	ELECTROLYTIC CAP. 1μF/50V M or	CE1JMASTL1R0
	ELECTROLYTIC CAP. 1μF/50V M or	CE1JMASTL010
	ELECTROLYTIC CAP. 1μF/50V M or	CE1JMASDL1R0
	ELECTROLYTIC CAP. 1μF/50V M	CE1JMASDL010
C681	ELECTROLYTIC CAP. 100μF/10V M or	CE1AMASTL101
	ELECTROLYTIC CAP. 100μF/10V M	CE1AMASDL101
C682	ELECTROLYTIC CAP. 100μF/10V M or	CE1AMASTL101
	ELECTROLYTIC CAP. 100μF/10V M	CE1AMASDL101
C683	ELECTROLYTIC CAP. 100μF/10V M or	CE1AMASTL101
	ELECTROLYTIC CAP. 100μF/10V M	CE1AMASDL101
C686	ELECTROLYTIC CAP. 33μF/16V M or	CE1CMASSTL330
	ELECTROLYTIC CAP. 33μF/16V M	CE1CMASDL330
C687	ELECTROLYTIC CAP. 100μF/10V M or	CE1AMASTL101
	ELECTROLYTIC CAP. 100μF/10V M	CE1AMASDL101
C701	CHIP CERAMIC CAP. CH J 100pF/50V	CHD1JJBCH101
C711	CERAMIC CAP.(AX) X K 3300pF/16V	CDA1CKT0X332
C805	ELECTROLYTIC CAP. 220μF/16V M or	CE1CMASSTL221
	ELECTROLYTIC CAP. 220μF/16V M	CE1CMASDL221
C811	ELECTROLYTIC CAP. 470μF/16V M or	CE1CMASSTL471
	ELECTROLYTIC CAP. 470μF/16V M	CE1CMASDL471
C821	CHIP CERAMIC CAP. B K 6800pF/50V	CHD1JKB0B682
C822	CERAMIC CAP.(AX) F Z 0.22μF/50V	CA1J224TU014
C823	CERAMIC CAP.(AX) F Z 0.47μF/50V	CA1J474TU014
<b>CONNECTORS</b>		
CN301	CONNECTOR BASE, 5P TUC-P05P-B1	J3TUA05TG001
CN571▲	CONNECTOR BASE, 5P TV-50P-05-V3 or	J3TVC05TG002
▲	CONNECTOR BASE, 5P RTB-1.5-5P or	J3RTC05JG001
▲	CONNECTOR BASE, 5P W-P3005-02	1730812
CN691▲	CONNECTOR BASE, 2P TV-50P-02-V3 or	J3TVC02TG002
▲	CONNECTOR BASE, 2P RTB-1.5-2P	J3RTC02JG001

Ref. No.	Description	Part No.
CN801	STRAIGHT CONNECTOR BASE 00 8283 0212 00 000 or	J383C02UG002
	STRAIGHT PIN HEADER, 2P 173981-2	1770258
<b>DIODES</b>		
D103	ZENER DIODE MTZJT-775.6B	QDTB0MTZJ5R6
D104	ZENER DIODE MTZJT-775.6B	QDTB0MTZJ5R6
D134▲	ZENER DIODE MTZJT-775.6B	QDTB0MTZJ5R6
D181▲	SWITCHING DIODE 1SS133(T-77) or	QDTZ001SS133
▲	SWITCHING DIODE 1N4148 or	NDTZ001N4148
▲	DIODE 1SS176TPA7	1SS176T
D311	SWITCHING DIODE 1SS133(T-77) or	QDTZ001SS133
	SWITCHING DIODE 1N4148 or	NDTZ001N4148
	DIODE 1SS176TPA7	1SS176T
D312	SWITCHING DIODE 1SS133(T-77) or	QDTZ001SS133
	SWITCHING DIODE 1N4148 or	NDTZ001N4148
	DIODE 1SS176TPA7	1SS176T
D313	SWITCHING DIODE 1SS133(T-77) or	QDTZ001SS133
	SWITCHING DIODE 1N4148 or	NDTZ001N4148
	DIODE 1SS176TPA7	1SS176T
D324	SWITCHING DIODE 1SS133(T-77) or	QDTZ001SS133
	SWITCHING DIODE 1N4148 or	NDTZ001N4148
	DIODE 1SS176TPA7	1SS176T
D393	ZENER DIODE MTZJT-775.6B	QDTB0MTZJ5R6
D396	ZENER DIODE MTZJT-778.2B	QDTB0MTZJ8R2
D397	SWITCHING DIODE 1SS133(T-77) or	QDTZ001SS133
	SWITCHING DIODE 1N4148 or	NDTZ001N4148
	DIODE 1SS176TPA7	1SS176T
D551	DIODE 1N5397-B or	NDLZ001N5397
	RECTIFIER DIODE ERB12-06	QDQZ0ERB1206
D568▲	SWITCHING DIODE 1SS133(T-77) or	QDTZ001SS133
▲	SWITCHING DIODE 1N4148 or	NDTZ001N4148
▲	DIODE 1SS176TPA7	1SS176T
D569▲	ZENER DIODE MTZJT-7720B	QDTB00MTZJ20
D571	DIODE FR104-B or	NDLZ000FR104
	RECTIFIER DIODE ERA22-02 or	QDPZ0ERA2202
	RECTIFIER DIODE 10ELS2	QDQZ0010ELS2
D572▲	DIODE FR104-B or	NDLZ000FR104
▲	RECTIFIER DIODE ERA22-02 or	QDPZ0ERA2202
▲	RECTIFIER DIODE 10ELS2	QDQZ0010ELS2
D573▲	DIODE FR104-B or	NDLZ000FR104
▲	RECTIFIER DIODE ERA22-02 or	QDPZ0ERA2202
▲	RECTIFIER DIODE 10ELS2	QDQZ0010ELS2
D584▲	SWITCHING DIODE 1SS133(T-77) or	QDTZ001SS133
▲	SWITCHING DIODE 1N4148 or	NDTZ001N4148
▲	DIODE 1SS176TPA7	1SS176T
D593▲	ZENER DIODE MTZJT-7736B	QDTB00MTZJ36
D597	ZENER DIODE MTZJT-776.8B	QDTB0MTZJ6R8
D605▲	DIODE 1N5397-B or	NDLZ001N5397
▲	RECTIFIER DIODE ERB12-06	QDQZ0ERB1206
D606▲	DIODE 1N5397-B or	NDLZ001N5397
▲	RECTIFIER DIODE ERB12-06	QDQZ0ERB1206
D607▲	DIODE 1N5397-B or	NDLZ001N5397
▲	RECTIFIER DIODE ERB12-06	QDQZ0ERB1206
D608▲	DIODE 1N5397-B or	NDLZ001N5397
▲	RECTIFIER DIODE ERB12-06	QDQZ0ERB1206
D611▲	ZENER DIODE MTZJT-7715B	QDTB00MTZJ15
D613▲	ZENER DIODE MTZJT-7715B	QDTB00MTZJ15
D615▲	SWITCHING DIODE 1N4148 T-77	QDTZ001N4148
D621	ZENER DIODE MTZJT-773.0B	QDTB0MTZJ3R0
D622	SWITCHING DIODE 1SS133(T-77) or	QDTZ001SS133
	SWITCHING DIODE 1N4148 or	NDTZ001N4148

Ref. No.	Description	Part No.
	DIODE 1SS176TPA7	1SS176T
D651▲	RECTIFIER DIODE 15DF4 or	QDQZ00015DF4
▲	RECOVERY DIODE ERC18-04 or	QDZZ0ERC1804
▲	FAST RECOVERY DIODE ERC25-06	QDQZ0ERC2506
D652▲	DIODE FR154 or	NDLZ000FR154
▲	FAST RECOVERY DIODE ERB44-02	QDPZ0ERB4402
D653▲	DIODE FR154 or	NDLZ000FR154
▲	FAST RECOVERY DIODE ERB44-02	QDPZ0ERB4402
D654▲	SWITCHING DIODE 1SS133(T-77) or	QDTZ001SS133
▲	SWITCHING DIODE 1N4148 or	NDTZ001N4148
▲	DIODE 1SS176TPA7	1SS176T
D657▲	DIODE 1ZC33 or	QDQZ0001ZC33
▲	ZENER DIODE RD33FB	QDQZ000RD33F
D660	SWITCHING DIODE 1SS133(T-77) or	QDTZ001SS133
	SWITCHING DIODE 1N4148 or	NDTZ001N4148
	DIODE 1SS176TPA7	1SS176T
D661	SWITCHING DIODE 1SS133(T-77) or	QDTZ001SS133
	SWITCHING DIODE 1N4148 or	NDTZ001N4148
	DIODE 1SS176TPA7	1SS176T
D662▲	ZENER DIODE MTZJT-776.8B	QDTB0MTZJ6R8
D666▲	ZENER DIODE MTZJT-7736B	QDTB00MTZJ36
D671▲	SWITCHING DIODE 1SS133(T-77) or	QDTZ001SS133
▲	SWITCHING DIODE 1N4148 or	NDTZ001N4148
▲	DIODE 1SS176TPA7	1SS176T
D672	SWITCHING DIODE 1SS133(T-77) or	QDTZ001SS133
	SWITCHING DIODE 1N4148 or	NDTZ001N4148
	DIODE 1SS176TPA7	1SS176T
D673	SWITCHING DIODE 1SS133(T-77) or	QDTZ001SS133
	SWITCHING DIODE 1N4148 or	NDTZ001N4148
	DIODE 1SS176TPA7	1SS176T
D682▲	ZENER DIODE MTZJT-775.6B	QDTB0MTZJ5R6
D691▲	SWITCHING DIODE 1SS133(T-77) or	QDTZ001SS133
▲	SWITCHING DIODE 1N4148 or	NDTZ001N4148
▲	DIODE 1SS176TPA7	1SS176T
D692	SWITCHING DIODE 1SS133(T-77) or	QDTZ001SS133
	SWITCHING DIODE 1N4148 or	NDTZ001N4148
	DIODE 1SS176TPA7	1SS176T
D801	PCB JUMPER D0.6-P5.0	JW5.0T
D802	CARBON RES. 1/2W J 100 Ω or	RCX2JZQZ0101
	CARBON RES. 1/2W J 100 Ω or	RCX2101KA013
	CARBON RES. 1/2W J 100 Ω	RCX2JZPZ0101
D811▲	SWITCHING DIODE 1SS133(T-77) or	QDTZ001SS133
▲	SWITCHING DIODE 1N4148 or	NDTZ001N4148
▲	DIODE 1SS176TPA7	1SS176T
D826	SWITCHING DIODE 1SS133(T-77) or	QDTZ001SS133
	SWITCHING DIODE 1N4148 or	NDTZ001N4148
	DIODE 1SS176TPA7	1SS176T
<b>ICS</b>		
IC101▲	IC:TV MICOM M3727GM8-054FP	QSZAA0SMB054
IC151	IC:MEMORY AT24C01A-10SC or	NSMMA0SAZ011
	IC:(EEPROM) M24C01-MN6 or	NSMMA0SSS027
	IC:MEMORY BR24C01AF-W or	QSMBA0SRM002
	IC:MEMORY BR24C01AF	QSMMA0SRM002
IC333▲	IC:CHROMA/IF 1 CHIP M61206FP-61 or	QSZAB0RMB011
▲	IC:CHROMA/IF 1 CHIP M61206FP	QSZAA0RMB011
IC551▲	VERTICAL OUTPUT IC LA78040A or	QSBBA0SSY003
▲	VERTICAL OUTPUT IC AN5522	QSZBA0SMS002
IC601▲	PHOTO COUPLER PF5001-B,C or	QPE300PF5001
▲	PHOTOCOUPLER LTV-817B-F or	NPEB0LTV817F
▲	PHOTOCOUPLER LTV-817C-F	NPEC0LTV817F

Ref. No.	Description	Part No.
IC801	AUDIO AMP LA4524L	QSBLA0SSY087
<b>COILS</b>		
L5	INDUCTOR 22 $\mu$ H-K-5FT or INDUCTOR 22 $\mu$ H-K	LLARKBSTU220 LLARKDQKA220
L11	PCB JUMPER D0.6-P5.0	JW5.0T
L15	INDUCTOR 0.82 $\mu$ H-J-26T	LLAXJATTUR82
L111	INDUCTOR 22 $\mu$ H-K-5FT or INDUCTOR 22 $\mu$ H-K	LLARKBSTU220 LLARKDQKA220
L112	INDUCTOR 22 $\mu$ H-J-26T or INDUCTOR 22 $\mu$ H-K-26T	LLAXJATTU220 LLAXKDTKA220
L302	PCB JUMPER D0.6-P5.0	JW5.0T
L304	INDUCTOR 1.0 $\mu$ H-K-26T or INDUCTOR 1.0 $\mu$ H-K-26T	LLAXKATTU1R0 LLAXKDTKA1R0
L325	INDUCTOR 100 $\mu$ H-K-5FT or INDUCTOR 100 $\mu$ H-K	LLARKBSTU101 LLARKDQKA101
L361	INDUCTOR 10 $\mu$ H-J-26T or INDUCTOR 10 $\mu$ H-K-26T	LLAXJATTU100 LLAXKDTKA100
L373	INDUCTOR 3.3 $\mu$ H-J-26T or INDUCTOR 3.3 $\mu$ H-K-26T	LLAXJATTU3R3 LLAXKDTKA3R3
L601▲	LINE FILTER TLF12UA302W1R0 or ▲ LINE FILTER 5.0MH 6Y075 or ▲ LINE FILTER LF005 or ▲ LINE FILTER UU10.5-A or ▲ LINE FILTER SA-91213B or ▲ LINE FILTER TLF14CB3321R0	LLBG00ZTU025 LLBG00ZKT004 LLBG00ZLH001 LLBG00ZY2008 LLBG00ZSA002 LLBG00ZTU012
L692	PCB JUMPER D0.6-P7.5	JW7.5T
<b>TRANSISTORS</b>		
Q111	TRANSISTOR 2SC2785(F) or TRANSISTOR 2SC2785(H) or TRANSISTOR 2SC2785(J) or TRANSISTOR KTC3199(GR) or TRANSISTOR KTC3198GR TO-92 or TRANSISTOR 2SC3331(T)-AANP or TRANSISTOR 2SC3331(U)-AANP or TRANSISTOR 2SC1815-GR(TPE2)	QQSF02SC2785 QQSH02SC2785 QQSJ02SC2785 NQS10KTC3199 NQS40KTC3198 2SC3331TZ 2SC3331UZ QQS102SC1815
Q571▲	TRANSISTOR TT2084LS-YB11 or ▲ TRANSISTOR 2SD2627LS-FEC-YB11	QQZZ00TT2084 QQZZ02SD2627
Q572	TRANSISTOR 2SC1627Y-TPE2	QQSY02SC1627
Q601▲	MOS FET 2SK2872-54MR or ▲ MOS FET 2SK2662	QFZZ02SK2872 QF5Z02SK2662
Q602▲	TRANSISTOR 2SC2120-O-TPE2 or ▲ TRANSISTOR 2SC2120-Y(TPE2)	QQS002SC2120 QQSY02SC2120
Q662▲	TRANSISTOR 2SC2785(F) or ▲ TRANSISTOR 2SC2785(H) or ▲ TRANSISTOR 2SC2785(J) or ▲ TRANSISTOR KTC3199(GR) or ▲ TRANSISTOR KTC3198GR TO-92 or ▲ TRANSISTOR 2SC3331(T)-AANP or ▲ TRANSISTOR 2SC3331(U)-AANP or ▲ TRANSISTOR 2SC1815-GR(TPE2)	QQSF02SC2785 QQSH02SC2785 QQSJ02SC2785 NQS10KTC3199 NQS40KTC3198 2SC3331TZ 2SC3331UZ QQS102SC1815
Q671▲	TRANSISTOR 2SA1175(F) or ▲ TRANSISTOR KTA1267(GR) or ▲ TRANSISTOR KTA1266(GR) or ▲ TRANSISTOR 2SA1318(T)-AANP or ▲ TRANSISTOR 2SA1318(U)-AANP or ▲ TRANSISTOR 2SA1015-GR(TPE2)	QQSF02SA1175 NQS10KTA1267 NQS40KTA1266 2SA1318TZ 2SA1318UZ QQS102SA1015
Q676	RES. BUILT-IN TRANSISTOR BA1F4M-T or RES. BUILT-IN TRANSISTOR KRC103M	QQSZ00BA1F4M NQSZ0KRC103M
Q681	TRANSISTOR 2SC2120-O-TPE2 or TRANSISTOR 2SC2120-Y(TPE2)	QQS002SC2120 QQSY02SC2120

Ref. No.	Description	Part No.
Q682	TRANSISTOR 2SC2120-O-TPE2 or TRANSISTOR 2SC2120-Y(TPE2)	QQS002SC2120 QQSY02SC2120
Q683	TRANSISTOR 2SC2120-O-TPE2 or TRANSISTOR 2SC2120-Y(TPE2)	QQS002SC2120 QQSY02SC2120
Q831	TRANSISTOR 2SC2785(F) or TRANSISTOR 2SC2785(H) or TRANSISTOR 2SC2785(J) or TRANSISTOR KTC3199(GR) or TRANSISTOR KTC3198GR TO-92 or TRANSISTOR 2SC3331(T)-AANP or TRANSISTOR 2SC3331(U)-AANP or TRANSISTOR 2SC1815-GR(TPE2)	QQSF02SC2785 QQSH02SC2785 QQSJ02SC2785 NQS10KTC3199 NQS40KTC3198 2SC3331TZ 2SC3331UZ QQS102SC1815
<b>RESISTORS</b>		
J104	CHIP RES. 1/10W J 0 $\Omega$	RRXAJB5Z0000
J115	CHIP RES. 1/10W J 0 $\Omega$	RRXAJB5Z0000
J183	CHIP RES. 1/10W J 0 $\Omega$	RRXAJB5Z0000
R101	CHIP RES.(1608) 1/10W J 2.2k $\Omega$	RRXAJB5Z0222
R102	CHIP RES.(1608) 1/10W J 1.8k $\Omega$	RRXAJB5Z0182
R103	CHIP RES.(1608) 1/10W J 3.3k $\Omega$	RRXAJB5Z0332
R104	CHIP RES.(1608) 1/10W J 4.7k $\Omega$	RRXAJB5Z0472
R105	CHIP RES.(1608) 1/10W J 8.2k $\Omega$	RRXAJB5Z0822
R106	CHIP RES.(1608) 1/10W J 10k $\Omega$	RRXAJB5Z0103
R107	CHIP RES.(1608) 1/10W J 2.2k $\Omega$	RRXAJB5Z0222
R111	CARBON RES. 1/4W J 100 $\Omega$ or CARBON RES. 1/6W J 100 $\Omega$	RCX4JATZ0101 RCX6JATZ0101
R121	CHIP RES.(1608) 1/10W J 4.7k $\Omega$	RRXAJB5Z0472
R122	CHIP RES.(1608) 1/10W J 4.7k $\Omega$	RRXAJB5Z0472
R123	CHIP RES.(1608) 1/10W J 4.7k $\Omega$	RRXAJB5Z0472
R124	CHIP RES.(1608) 1/10W J 4.7k $\Omega$	RRXAJB5Z0472
R125	CHIP RES.(1608) 1/10W J 1.5k $\Omega$	RRXAJB5Z0152
R126	CHIP RES.(1608) 1/10W J 1.5k $\Omega$	RRXAJB5Z0152
R127	CHIP RES.(1608) 1/10W J 1.5k $\Omega$	RRXAJB5Z0152
R128	CHIP RES.(1608) 1/10W J 3.3k $\Omega$	RRXAJB5Z0332
R131	CHIP RES.(1608) 1/10W J 3.3k $\Omega$	RRXAJB5Z0332
R132	CHIP RES.(1608) 1/10W J 3.3k $\Omega$	RRXAJB5Z0332
R133	CHIP RES.(1608) 1/10W J 4.7k $\Omega$	RRXAJB5Z0472
R134▲	CHIP RES.(1608) 1/10W J 1k $\Omega$	RRXAJB5Z0102
R135	CHIP RES.(1608) 1/10W J 10k $\Omega$	RRXAJB5Z0103
R136	CARBON RES. 1/4W J 22k $\Omega$ or CARBON RES. 1/6W J 22k $\Omega$	RCX4JATZ0223 RCX6JATZ0223
R155	CHIP RES.(1608) 1/10W J 100 $\Omega$	RRXAJB5Z0101
R164	CHIP RES.(1608) 1/10W J 6.8k $\Omega$	RRXAJB5Z0682
R165	CHIP RES. 1/10W J 0 $\Omega$	RRXAJB5Z0000
R171	CHIP RES.(1608) 1/10W J 100 $\Omega$	RRXAJB5Z0101
R172	CHIP RES.(1608) 1/10W J 1k $\Omega$	RRXAJB5Z0102
R176	CHIP RES.(1608) 1/10W J 390k $\Omega$	RRXAJB5Z0394
R181	CHIP RES.(1608) 1/10W J 100 $\Omega$	RRXAJB5Z0101
R182	CHIP RES.(1608) 1/10W J 100 $\Omega$	RRXAJB5Z0101
R303	CHIP RES.(1608) 1/10W J 2.2k $\Omega$	RRXAJB5Z0222
R305	CHIP RES.(1608) 1/10W J 10k $\Omega$	RRXAJB5Z0103
R306	CHIP RES.(1608) 1/10W J 2.7k $\Omega$	RRXAJB5Z0272
R307	CHIP RES. 1/10W J 0 $\Omega$	RRXAJB5Z0000
R308	CHIP RES.(1608) 1/10W J 100 $\Omega$	RRXAJB5Z0101
R309	CHIP RES.(1608) 1/10W J 6.8k $\Omega$	RRXAJB5Z0682
R310	CARBON RES. 1/4W J 2.2k $\Omega$ or CARBON RES. 1/6W J 2.2k $\Omega$	RCX4JATZ0222 RCX6JATZ0222
R311	CHIP RES.(1608) 1/10W J 2.2k $\Omega$	RRXAJB5Z0222
R312	CHIP RES.(1608) 1/10W J 2.2k $\Omega$	RRXAJB5Z0222
R313	CHIP RES.(1608) 1/10W J 2.2k $\Omega$	RRXAJB5Z0222
R314	CHIP RES.(1608) 1/10W J 100 $\Omega$	RRXAJB5Z0101

Ref. No.	Description	Part No.
R315	CHIP RES.(1608) 1/10W J 100 Ω	RRXAJB5Z0101
R316	CHIP RES.(1608) 1/10W J 100 Ω	RRXAJB5Z0101
R320	PCB JUMPER D0.6-P5.0	JW5.0T
R321	CARBON RES. 1/4W J 1k Ω or	RCX4JATZ0102
	CARBON RES. 1/6W J 1k Ω	RCX6JATZ0102
R323	CARBON RES. 1/4W J 22k Ω or	RCX4JATZ0223
	CARBON RES. 1/6W J 22k Ω	RCX6JATZ0223
R324	CARBON RES. 1/4W J 10 Ω or	RCX4JATZ0100
	CARBON RES. 1/6W J 10 Ω	RCX6JATZ0100
R325	CARBON RES. 1/4W J 180k Ω or	RCX4JATZ0184
	CARBON RES. 1/6W J 180k Ω	RCX6JATZ0184
R326	CHIP RES.(1608) 1/10W J 470 Ω	RRXAJB5Z0471
R332	CARBON RES. 1/4W J 15k Ω or	RCX4JATZ0153
	CARBON RES. 1/6W J 15k Ω	RCX6JATZ0153
R333	CARBON RES. 1/4W J 82k Ω or	RCX4JATZ0823
	CARBON RES. 1/6W J 82k Ω	RCX6JATZ0823
R334	CHIP RES.(1608) 1/10W J 120k Ω	RRXAJB5Z0124
R341	CHIP RES.(1608) 1/10W J 6.8k Ω	RRXAJB5Z0682
R343	CHIP RES.(1608) 1/10W J 100 Ω	RRXAJB5Z0101
R346	CARBON RES. 1/4W J 100 Ω or	RCX4JATZ0101
	CARBON RES. 1/6W J 100 Ω	RCX6JATZ0101
R347	CHIP RES.(1608) 1/10W J 10k Ω	RRXAJB5Z0103
R348	CARBON RES. 1/4W J 220 Ω or	RCX4JATZ0221
	CARBON RES. 1/6W J 220 Ω	RCX6JATZ0221
R351	PCB JUMPER D0.6-P5.0	JW5.0T
R352	PCB JUMPER D0.6-P5.0	JW5.0T
R361	CHIP RES.(1608) 1/10W J 82 Ω	RRXAJB5Z0820
R364	CHIP RES.(1608) 1/10W J 100 Ω	RRXAJB5Z0101
R367	CHIP RES. 1/10W J 0 Ω	RRXAJB5Z0000
R368	CHIP RES.(1608) 1/10W J 10M Ω	RRXAJB5Z0106
R369	CHIP RES.(1608) 1/10W J 15k Ω	RRXAJB5Z0153
R371	CHIP RES.(1608) 1/10W J 470 Ω	RRXAJB5Z0471
R373	CHIP RES.(1608) 1/10W J 390 Ω	RRXAJB5Z0391
R380	CHIP RES.(1608) 1/10W J 100 Ω	RRXAJB5Z0101
R391	CHIP RES.(1608) 1/10W J 100 Ω	RRXAJB5Z0101
R392	CHIP RES.(1608) 1/10W J 100 Ω	RRXAJB5Z0101
R393	CHIP RES.(1608) 1/10W J 1k Ω	RRXAJB5Z0102
R396	CARBON RES. 1/4W J 220 Ω or	RCX4JATZ0221
	CARBON RES. 1/6W J 220 Ω	RCX6JATZ0221
R397	CARBON RES. 1/4W J 220 Ω or	RCX4JATZ0221
	CARBON RES. 1/6W J 220 Ω	RCX6JATZ0221
R551	CARBON RES. 1/4W J 4.7 Ω or	RCX4JATZ04R7
	CARBON RES. 1/6W J 4.7 Ω	RCX6JATZ04R7
R552▲	CARBON RES. 1/4W J 1 Ω or	RCX4JATZ01R0
▲	CARBON RES. 1/6W J 1 Ω	RCX6JATZ01R0
R553	CARBON RES. 1/4W J 1 Ω or	RCX4JATZ01R0
	CARBON RES. 1/6W J 1 Ω	RCX6JATZ01R0
R554▲	CARBON RES. 1/4W J 3.9 Ω or	RCX4JATZ03R9
▲	CARBON RES. 1/6W J 3.9 Ω	RCX6JATZ03R9
R556	CARBON RES. 1/4W J 1k Ω or	RCX4JATZ0102
	CARBON RES. 1/6W J 1k Ω	RCX6JATZ0102
R557	CARBON RES. 1/4W J 1k Ω or	RCX4JATZ0102
	CARBON RES. 1/6W J 1k Ω	RCX6JATZ0102
R558	CARBON RES. 1/4W J 3.3k Ω or	RCX4JATZ0332
	CARBON RES. 1/6W J 3.3k Ω	RCX6JATZ0332
R559	CARBON RES. 1/4W J 3.3k Ω or	RCX4JATZ0332
	CARBON RES. 1/6W J 3.3k Ω	RCX6JATZ0332
R561	CHIP RES.(1608) 1/10W J 470 Ω	RRXAJB5Z0471
R562	CHIP RES.(1608) 1/10W J 2.7k Ω	RRXAJB5Z0272
R563▲	CHIP RES.(1608) 1/10W J 10k Ω	RRXAJB5Z0103
R564	CHIP RES.(1608) 1/10W J 22k Ω	RRXAJB5Z0223

Ref. No.	Description	Part No.
R566	CARBON RES. 1/4W J 2.2 Ω or	RCX4JATZ02R2
	CARBON RES. 1/6W J 2.2 Ω	RCX6JATZ02R2
R569▲	CHIP RES.(1608) 1/10W J 6.8k Ω	RRXAJB5Z0682
R571▲	METAL OXIDE FILM RES. 2W J 470 Ω or	RN02471KE009
▲	METAL OXIDE FILM RES. 2W J 470 Ω or	RN02471ZU001
▲	METAL RESISTOR 2W J 470 Ω or	RN02471UB001
▲	METAL OXIDE FILM RES. 2W J 470 Ω	RN02471DP004
R575▲	CARBON RES. 1/4W J 47 Ω or	RCX4JATZ0470
▲	CARBON RES. 1/6W J 47 Ω	RCX6JATZ0470
R576▲	CARBON RES. 1/4W J 47 Ω or	RCX4JATZ0470
▲	CARBON RES. 1/6W J 47 Ω	RCX6JATZ0470
R577▲	PCB JUMPER D0.6-P5.0	JW5.0T
R578	CARBON RES. 1/4W J 560 Ω or	RCX4JATZ0561
	CARBON RES. 1/6W J 560 Ω	RCX6JATZ0561
R579	CARBON RES. 1/4W J 1k Ω or	RCX4JATZ0102
	CARBON RES. 1/6W J 1k Ω	RCX6JATZ0102
R581	PCB JUMPER D0.6-P5.0	JW5.0T
R583▲	METAL FILM RES.(STRAIGHT)2W J 1.8 Ω or	RN02JZQZ01R8
▲	METAL FILM RES.(STRAIGHT)2W J 1.8 Ω or	RN02JZPZ01R8
▲	METAL OXIDE FILM RES. 2W J 1.8 Ω	RN021R8ZU001
R584▲	CARBON RES. 1/4W J 1k Ω or	RCX4JATZ0102
▲	CARBON RES. 1/6W J 1k Ω	RCX6JATZ0102
R588▲	CARBON RES. 1/4W J 100k Ω or	RCX4JATZ0104
▲	CARBON RES. 1/6W J 100k Ω	RCX6JATZ0104
R589	CARBON RES. 1/4W J 100k Ω or	RCX4JATZ0104
	CARBON RES. 1/6W J 100k Ω	RCX6JATZ0104
R591▲	CHIP RES.(1608) 1/10W J 180k Ω	RRXAJB5Z0184
R592▲	CHIP RES.(1608) 1/10W J 100k Ω	RRXAJB5Z0104
R593▲	CHIP RES.(1608) 1/10W J 68k Ω	RRXAJB5Z0683
R594▲	CHIP RES.(1608) 1/10W J 100k Ω	RRXAJB5Z0104
R597	CARBON RES. 1/4W J 8.2k Ω or	RCX4JATZ0822
	CARBON RES. 1/6W J 8.2k Ω	RCX6JATZ0822
R598▲	CARBON RES. 1/4W J 47k Ω or	RCX4JATZ0473
▲	CARBON RES. 1/6W J 47k Ω	RCX6JATZ0473
R599▲	CHIP RES.(1608) 1/10W J 22k Ω	RRXAJB5Z0223
R601▲	CEMENT RES. 5W K 1.2 Ω or	RW051R2DP005
▲	CEMENT RESISTOR 5W K 1.2 Ω or	RW051R2PG001
▲	CEMENT RESISTOR SQZ05S1R2J or	RW051R2Y4001
▲	CEMENT RES. 3W J 1.2 Ω	RW031R2PG007
R602	CARBON RES. 1/4W J 820k Ω or	RCX4JATZ0824
	CARBON RES. 1/6W J 820k Ω	RCX6JATZ0824
R603	CARBON RES. 1/4W J 820k Ω or	RCX4JATZ0824
	CARBON RES. 1/6W J 820k Ω	RCX6JATZ0824
R611	CARBON RES. 1/4W J 270 Ω or	RCX4JATZ0271
	CARBON RES. 1/6W J 270 Ω	RCX6JATZ0271
R612	CARBON RES. 1/4W J 270 Ω or	RCX4JATZ0271
	CARBON RES. 1/6W J 270 Ω	RCX6JATZ0271
R613▲	FIXED METAL OXIDE FILM RES. 2W J 0.47 Ω or	RN02JZQZ0R47
▲	METAL RES. 2W J 0.47 Ω or	RN02JZPZ0R47
▲	METAL OXIDE FILM RES. 2W J 0.47 Ω	RN02R47ZU001
R614	CARBON RES. 1/4W J 47 Ω or	RCX4JATZ0470
	CARBON RES. 1/6W J 47 Ω	RCX6JATZ0470
R616	CARBON RES. 1/4W J 10k Ω or	RCX4JATZ0103
	CARBON RES. 1/6W J 10k Ω	RCX6JATZ0103
R621	CARBON RES. 1/4W J 1.5k Ω or	RCX4JATZ0152
	CARBON RES. 1/6W J 1.5k Ω	RCX6JATZ0152
R622	CARBON RES. 1/4W J 10k Ω or	RCX4JATZ0103
	CARBON RES. 1/6W J 10k Ω	RCX6JATZ0103
R623	CARBON RES. 1/4W J 330 Ω or	RCX4JATZ0331
	CARBON RES. 1/6W J 330 Ω	RCX6JATZ0331



Ref. No.	Description	Part No.
R624	PCB JUMPER D0.6-P5.0	JW5.0T
R653	CHIP RES.(1608) 1/10W J 15k Ω	RRXAJB5Z0153
R654▲	CARBON RES. 1/4W J 3.3k Ω or	RCX4JATZ0332
▲	CARBON RES. 1/6W J 3.3k Ω	RCX6JATZ0332
R655	CARBON RES. 1/4W J 1k Ω or	RCX4JATZ0102
	CARBON RES. 1/6W J 1k Ω	RCX6JATZ0102
R656▲	CHIP RES.(1608) 1/10W J 15k Ω	RRXAJB5Z0153
R657▲	CARBON RES. 1/4W J 15k Ω or	RCX4JATZ0153
▲	CARBON RES. 1/6W J 15k Ω	RCX6JATZ0153
R660	CARBON RES. 1/4W J 1k Ω or	RCX4JATZ0102
	CARBON RES. 1/6W J 1k Ω	RCX6JATZ0102
R661▲	CARBON RES. 1/4W J 33k Ω or	RCX4JATZ0333
▲	CARBON RES. 1/6W J 33k Ω	RCX6JATZ0333
R662▲	CARBON RES. 1/4W J 180k Ω or	RCX4JATZ0184
▲	CARBON RES. 1/6W J 180k Ω	RCX6JATZ0184
R664▲	CHIP RES.(1608) 1/10W J 12k Ω	RRXAJB5Z0123
R665▲	CHIP RES.(1608) 1/10W J 4.7k Ω	RRXAJB5Z0472
R666▲	METAL OXIDE FILM RES. 2W J 12k Ω or	RN02123KE009
▲	METAL OXIDE FILM RES. 2W J 12k Ω or	RN02123ZU001
▲	METAL RESISTOR 2W J 12k Ω or	RN02123UB001
▲	METAL OXIDE FILM RES. 2W J 12k Ω	RN02123DP004
R667▲	PCB JUMPER D0.6-P5.0	JW5.0T
R668▲	METAL OXIDE FILM RES. 1W J 56k Ω or	RN01563KE009
▲	METAL OXIDE FILM RES. 1W J 56k Ω or	RN01563ZU001
▲	METAL OXIDE RESISTOR 1W J 56k Ω or	RN01563UB001
▲	METAL OXIDE FILM RES. 1W J 56k Ω	RN01563DP003
R671	CARBON RES. 1/4W J 3.3k Ω or	RCX4JATZ0332
	CARBON RES. 1/6W J 3.3k Ω	RCX6JATZ0332
R672	CARBON RES. 1/4W J 3.3k Ω or	RCX4JATZ0332
	CARBON RES. 1/6W J 3.3k Ω	RCX6JATZ0332
R673	CARBON RES. 1/4W J 100k Ω or	RCX4JATZ0104
	CARBON RES. 1/6W J 100k Ω	RCX6JATZ0104
R676	CARBON RES. 1/4W J 10k Ω or	RCX4JATZ0103
	CARBON RES. 1/6W J 10k Ω	RCX6JATZ0103
R681▲	CARBON RES. 1/4W J 12 Ω or	RCX4JATZ0120
▲	CARBON RES. 1/6W J 12 Ω	RCX6JATZ0120
R682▲	FIXED METAL OXIDE FILM RES. 1W J 33 Ω or	RN01330KE007
▲	METAL OXIDE FILM RES. 1W J 33 Ω or	RN01330ZU001
▲	METAL RES. 1W J 33 Ω or	RN01330UB001
▲	METAL OXIDE FILM RES. 1W J 33 Ω	RN01330DP003
R683▲	FIXED METAL OXIDE FILM RES. 1W J 39 Ω or	RN01390KE007
▲	METAL OXIDE FILM RES. 1W J 39 Ω or	RN01390ZU001
▲	FIXED METAL OXIDE FILM RES. 1W J 39 Ω or	RN01390UB001
▲	METAL OXIDE FILM RES. 1W J 39 Ω	RN01390DP003
R686	CARBON RES. 1/4W J 100 Ω or	RCX4JATZ0101
	CARBON RES. 1/6W J 100 Ω	RCX6JATZ0101
R687	CARBON RES. 1/4W J 10 Ω or	RCX4JATZ0100
	CARBON RES. 1/6W J 10 Ω	RCX6JATZ0100
R691▲	CARBON RES. 1/4W J 15k Ω or	RCX4JATZ0153
▲	CARBON RES. 1/6W J 15k Ω	RCX6JATZ0153
R701	CHIP RES.(1608) 1/10W J 75 Ω	RRXAJB5Z0750
R702	CHIP RES. 1/10W J 0 Ω	RRXAJB5Z0000
R711	CHIP RES.(1608) 1/10W J 47k Ω	RRXAJB5Z0473
R712	CHIP RES.(1608) 1/10W J 1k Ω	RRXAJB5Z0102
R810▲	METAL OXIDE FILM RES. 1W J 8.2 Ω or	RN018R2ZU002
▲	METAL OXIDE FILM RES. 1W J 8.2 Ω or	RN018R2KE009
▲	METAL RESISTOR 1W J 8.2 Ω	RN018R2UB001
R811▲	CARBON RES. 1/4W J 2.2k Ω or	RCX4JATZ0222
▲	CARBON RES. 1/6W J 2.2k Ω	RCX6JATZ0222
R812▲	CHIP RES.(1608) 1/10W J 2.2k Ω	RRXAJB5Z0222
R821	CHIP RES.(1608) 1/10W J 15k Ω	RRXAJB5Z0153

Ref. No.	Description	Part No.
R822	CHIP RES.(1608) 1/10W J 2.2k Ω	RRXAJB5Z0222
R826	CARBON RES. 1/4W J 470k Ω or	RCX4JATZ0474
	CARBON RES. 1/6W J 470k Ω	RCX6JATZ0474
R831	CHIP RES.(1608) 1/10W J 1k Ω	RRXAJB5Z0102
<b>SWITCHES</b>		
SW101	TACT SWITCH SKQSAB or	SST0101AL038
	TACT SWITCH KSM0612B or	SST0101HH003
	TACT SWITCH SKHHAM	SST0101AL029
SW102	TACT SWITCH SKQSAB or	SST0101AL038
	TACT SWITCH KSM0612B or	SST0101HH003
	TACT SWITCH SKHHAM	SST0101AL029
SW103	TACT SWITCH SKQSAB or	SST0101AL038
	TACT SWITCH KSM0612B or	SST0101HH003
	TACT SWITCH SKHHAM	SST0101AL029
SW104	TACT SWITCH SKQSAB or	SST0101AL038
	TACT SWITCH KSM0612B or	SST0101HH003
	TACT SWITCH SKHHAM	SST0101AL029
SW105	TACT SWITCH SKQSAB or	SST0101AL038
	TACT SWITCH KSM0612B or	SST0101HH003
	TACT SWITCH SKHHAM	SST0101AL029
SW106	TACT SWITCH SKQSAB or	SST0101AL038
	TACT SWITCH KSM0612B or	SST0101HH003
	TACT SWITCH SKHHAM	SST0101AL029
<b>MISCELLANEOUS</b>		
AC601▲	AC CORD LA-2366 or	WAC0172LW006
▲	AC CORD WAC0172AS006 or	WAC0172AS006
▲	AC CORD WAC0172LTE01	WAC0172LTE01
B-6	HEAT SINK(PFC)ASSEMBLY L7900UZ	0EM406060
B-7	HEAT SINK(PFA) L1400UZ	0EM406027
B-10	JACK HOLDER L9304UZ	0EM404325
B-12	CLOTH(65) L7735TR:65X10X0.5T	0EM402149
BC101	BEAD INDUCTORS FBR07HA121TB-00	LLBF00ZTU021
BC571	BEAD INDUCTORS FBA04HA600VB-00	LLBF00STU026
BC601	BEAD INDUCTORS FBR07HA121TB-00	LLBF00ZTU021
BC602	BEAD INDUCTORS FBR07HA121TB-00	LLBF00ZTU021
BC641	BEAD INDUCTORS FBR07HA121TB-00	LLBF00ZTU021
BC651	BEAD INDUCTORS FBR07HA121TB-00	LLBF00ZTU021
BC652	BEAD INDUCTORS FBR07HA121TB-00	LLBF00ZTU021
BC653	BEAD INDUCTORS FBR07HA121TB-00	LLBF00ZTU021
BC691	BEAD INDUCTORS FBR07HA121TB-00	LLBF00ZTU021
BC692	BEAD INDUCTORS FBR07HA121TB-00	LLBF00ZTU021
CF301	4.5M TRAP XT4.5MB2 or	FBE455PLN001
	CERAMIC TRAP 4.5MHz or	FBE455PMR003
	CERAMIC TRAP 4.5MHz	FBE455PMS001
CF302	4.5M FILTER LTH4.5MCB or	FBB455PLN001
	CERAMIC FILTER SFSRA4M50CF00-B0 or	FBB455PMR004
	CERAMIC FILTER 4.5MHz	FBB455PMS001
CLN301	WIRE ASSEMBLY WX1L9700-104	WX1L9700-104
F601▲	FUSE 4A/125V 237 TYPE or	PAGJ20CAG402
▲	FUSE TDS4A125VU/C or	PAGD20CW3402
▲	FUSE STC4A125V U/CT	PAGE20CW3402
FH601	FUSE HOLDER MSF-015 or	XH01Z00LY001
	FUSE HOLDER FH-V-03078 or	XH01Z00DK001
	HOLDER, FUSE CNT41-0014	1790424
FH602	FUSE HOLDER MSF-015 or	XH01Z00LY001
	FUSE HOLDER FH-V-03078 or	XH01Z00DK001
	HOLDER, FUSE CNT41-0014	1790424
GP641▲	GAP. FNR-G3.10D	FAZ000LD6005
JK701	RCA JACK 1P AV-8.4-9Y	JXRL010RP010
JK702	RCA JACK 1P AV-8.4-9W	JXRL010RP011

Ref. No.	Description	Part No.
JK801	EARPHONE JACK HTJ-035-1ZEBTZ or	JYSL030GE001
	EARPHONE JACK MSJ-035-12APC or	JYSL030LY001
	EARPHONE JACK HSJ1403-01-010 or	JYSL030HD002
	EARPHONE JACK LGY6501-0600	JYSL030SR001
L-1	B-TITE SCREW 3X8 BIND + CHROME or	GBMB3080
	B-TITE SCREW 3X8 BIND + CHROME	GBMB3080
PS691▲	THERMISTOR ZPB45BL7R0A	QNZZ45BL7R0A
RCV101	REMOCON RECEIVE UNIT PIC-26042SR-2 or	USESJRSKK032
	REMOCON RECEIVE UNIT PIC-37042SR	USESJRSKK034
SA601▲	SURGE ABSORBER AVR-S07D471KAAS or	QVQZ0AVRS07D
▲	VARISTOR ENC471D-07A or	QVQZ0471D07A
▲	SURGE ABSORBER JVR-07N471K	NVQZVR07N471
SF1	SAW FILTER SAFGP45M7VHBZL1B03 or	FBB456PMR003
	SAW FILTER SAFGP45M7VHBZL2B03	FBB456PMR004
T571▲	FLYBACK TRANSFORMER JF0501-2406 or	LTF00CPXB020
▲	FLYBACK TRANSFORMER BSC21-2601S or	LTF00CPS2026
▲	FLYBACK TRANS BSC25-0223	LTF00CPP1001
T572	HORIZONTAL DRIVE TRANS LP2-005	LTH00CPA5005
T601▲	SWITCHING TRANS K0F12F-0202 or	LTT00CPK065
▲	SWICHING TRANS SA-13L11	LTT00CPSA085
TP300	PCB JUMPER D0.6-P12.5	JW12.5T
TP301	PCB JUMPER D0.6-P15.0	JW15.0T
TP601	PCB JUMPER D0.6-P12.5	JW12.5T
TU1	TUNER TEDH9-300A or	UTUNNTUAL025
	TUNER B8095AP	UTUNNTUSP018
VR661	CARBON P.O.T. 30k Ω B or	VRCB303KA011
	CARBON P.O.T. 30k Ω B	VRCB303HH014
X101	CERAMIC RESONATOR KBR-8.0MKC or	FY0805PKC002
	CERAMIC RESONATOR CSTS0800MG03 or	FYL805PMR001
	CERAMIC RESONATOR ZTT 8.00MHz or	FY0805PLN001
	CERAMIC RESONATOR FCR8.0MC	FY0805PTE001
X331	XTAL 3.579545 MHz	FXD355LLN003

## CRT CBA

Ref. No.	Description	Part No.
	CRT CBA Consists of the following	-----
<b>CAPACITORS</b>		
C501	CHIP CERAMIC CAP. CH J 270pF/50V	CHD1JJBCH271
C502	CHIP CERAMIC CAP. CH J 270pF/50V	CHD1JJBCH271
C503	CHIP CERAMIC CAP. CH J 330pF/50V	CHD1JJBCH331
C504	ELECTROLYTIC CAP. 47μF/16V M or	CE1CMASL470
	ELECTROLYTIC CAP. 47μF/16V M	CE1CMASDL470
C510	CERAMIC CAP. B K 1000pF/2kV or	CCD3DKD0B102
	CERAMIC CAP. B K 1000pF/2kV or	CCD3DKP0B102
	CERAMIC CAP. B K 1000pF/2kV	CA3D102MR030
<b>CONNECTOR</b>		
CN501	PIN CONNECTOR 005P-5100	JTEA001TG001
<b>COIL</b>		
L501	INDUCTOR 180μH-J-5FT or	LLARJCASTU181
	INDUCTOR 180μH-K-5FT	LLARKDSKA181
<b>TRANSISTORS</b>		
Q501	TRANSISTOR 2SC2482 TPE6 or	QQSZ02SC2482
	TRANSISTOR 2SC3468(E)-AE or	QQSE02SC3468
	TRANSISTOR 2SC3468(D)-AE or	QQSD02SC3468
	TRANSISTOR 2SC2271(D)-AEMP or	2SC2271DZ
	TRANSISTOR 2SC2271(E)-AE	QQSE02SC2271
Q502	TRANSISTOR 2SC2482 TPE6 or	QQSZ02SC2482
	TRANSISTOR 2SC3468(E)-AE or	QQSE02SC3468
	TRANSISTOR 2SC3468(D)-AE or	QQSD02SC3468

Ref. No.	Description	Part No.
	TRANSISTOR 2SC2271(D)-AEMP or	2SC2271DZ
	TRANSISTOR 2SC2271(E)-AE	QQSE02SC2271
Q503	TRANSISTOR 2SC2482 TPE6 or	QQSZ02SC2482
	TRANSISTOR 2SC3468(E)-AE or	QQSE02SC3468
	TRANSISTOR 2SC3468(D)-AE or	QQSD02SC3468
	TRANSISTOR 2SC2271(D)-AEMP or	2SC2271DZ
	TRANSISTOR 2SC2271(E)-AE	QQSE02SC2271
<b>RESISTORS</b>		
R501▲	FIXED METAL OXIDE FILM RES. 1W J 15k Ω or	RN01153KE007
▲	METAL OXIDE FILM RES. 1W J 15k Ω or	RN01153ZU001
▲	METAL RESISTOR 1W J 15k Ω or	RN01153UB001
▲	METAL OXIDE FILM RES. 1W J 15k Ω	RN01153DP003
R502▲	FIXED METAL OXIDE FILM RES. 1W J 15k Ω or	RN01153KE007
▲	METAL OXIDE FILM RES. 1W J 15k Ω or	RN01153ZU001
▲	METAL RESISTOR 1W J 15k Ω or	RN01153UB001
▲	METAL OXIDE FILM RES. 1W J 15k Ω	RN01153DP003
R503▲	FIXED METAL OXIDE FILM RES. 1W J 15k Ω or	RN01153KE007
▲	METAL OXIDE FILM RES. 1W J 15k Ω or	RN01153ZU001
▲	METAL RESISTOR 1W J 15k Ω or	RN01153UB001
▲	METAL OXIDE FILM RES. 1W J 15k Ω	RN01153DP003
R504	CARBON RES. 1/4W J 1.5k Ω or	RCX4JATZ0152
	CARBON RES. 1/6W J 1.5k Ω	RCX6JATZ0152
R505	CARBON RES. 1/4W J 1.5k Ω or	RCX4JATZ0152
	CARBON RES. 1/6W J 1.5k Ω	RCX6JATZ0152
R506	CARBON RES. 1/4W J 1.5k Ω or	RCX4JATZ0152
	CARBON RES. 1/6W J 1.5k Ω	RCX6JATZ0152
R509	CARBON RES. 1/4W J 1.5k Ω or	RCX4JATZ0152
	CARBON RES. 1/6W J 1.5k Ω	RCX6JATZ0152
R511	CHIP RES.(1608) 1/10W J 33 Ω	RRXAJB5Z0330
R512	CHIP RES.(1608) 1/10W J 33 Ω	RRXAJB5Z0330
R513	CHIP RES.(1608) 1/10W J 33 Ω	RRXAJB5Z0330
R514	CARBON RES. 1/4W J 3.3k Ω or	RCX4JATZ0332
	CARBON RES. 1/6W J 3.3k Ω	RCX6JATZ0332
R515	CARBON RES. 1/4W J 3.3k Ω or	RCX4JATZ0332
	CARBON RES. 1/6W J 3.3k Ω	RCX6JATZ0332
R516	CARBON RES. 1/4W J 3.3k Ω or	RCX4JATZ0332
	CARBON RES. 1/6W J 3.3k Ω	RCX6JATZ0332
R517	CARBON RES. 1/4W J 560 Ω or	RCX4JATZ0561
	CARBON RES. 1/6W J 560 Ω	RCX6JATZ0561
R518	CARBON RES. 1/4W J 560 Ω or	RCX4JATZ0561
	CARBON RES. 1/6W J 560 Ω	RCX6JATZ0561
R519	CARBON RES. 1/4W J 560 Ω or	RCX4JATZ0561
	CARBON RES. 1/6W J 560 Ω	ΩRCX6JATZ0561
R537	CARBON RES. 1/4W J 1.5k Ω or	RCX4JATZ0152
	CARBON RES. 1/6W J 1.5k Ω	RCX6JATZ0152
R538	CARBON RES. 1/4W J 1.5k Ω or	RCX4JATZ0152
	CARBON RES. 1/6W J 1.5k Ω	RCX6JATZ0152
<b>MISCELLANEOUS</b>		
BC501	BEAD INDUCTORS FBR07HA121TB-00	LLBF00ZTU021
CLN501	PARALLEL WIRE L=250 3P	WX1L1000-102
JK501▲	CRT SOCKET ISMS02S	JSCC220PK003
TP501	PCB JUMPER D0.6-P10.0	JW10.0T
TP502	PCB JUMPER D0.6-P10.0	JW10.0T

6413CTB

L1304CE